

FERMEC[®]

SHARPCUT[®]
TECHNOLOGIES



**CATÁLOGO
LIMAS
ROTATIVAS**

ÍNDICE

DADOS DE FUNCIONAMENTO	03
TABELA DE VELOCIDADE DE CORTE.....	04
FORMATO DAS LINHAS ROTATIVAS	05
SA – FORMA CILÍNDRICA SEM CORTE FRONTAL	06
SB - FORMA CILÍNDRICA COM CORTE FRONTAL.....	07
SC - FORMA CILÍNDRICA PONTA ESFÉRICA.....	08
SD - FORMA ESFÉRICA	09
SE - FORMA OVAL.....	10
SF - FORMA DE ÁRVORE COM PONTA ESFÉRICA	11
SG - FORMA DE ÁRVORE COM PONTA AGUDA.....	12
SH - FORMA LABAREDA	13
SJ - FORMA CÔNICA 60°.....	14
SK - FORMA CÔNICA 90°	15
SL - FORMA CÔNICA COM PONTA ESFÉRICA	16
SM - FORMA CÔNICA	17
SN - FORMA CÔNICA INVERTIDA	18
LIMAS ROTATIVAS MOLDES E MATRIZES	19



SA - FORMA CILÍNDRICA SEM CORTE FRONTAL LONGA	20
SC - FORMA CILÍNDRICA PONTA ESFÉRICA LONGA	21
SD - FORMA ESFÉRICA LONGA.....	22
SE - FORMA OVAL LONGA	23
SF - FORMA DE ÁRVORE COM PONTA LONGA	24
SG - FORMA DE ÁRVORE COM PONTA AGUDA LONGA	25
SH - FORMA DE LABAREDA LONGA.....	26
SL - FORMA CÔNICA COM PONTA ESFÉRICA LONGA.....	27
SA - FORMA CILÍNDRICA SEM CORTE FRONTAL ALUMÍNIO..	28
SB - FORMA CILÍNDRICA COM CORTE FRONTAL ALUMÍNIO .	29
SC - FORMA CILÍNDRICA PONTA ESFÉRICA ALUMÍNIO	30
SD - FORMA ESFÉRICA ALUMÍNIO	31
SE - FORMA OVAL ALUMÍNIO	32
SF - FORMA DE ÁRVORE COM PONTA ESFÉRICA ALUMÍNIO	33
SG - FORMA DE ÁRVORE COM PONTA AGUDA ALUMÍNIO	34
SL - FORMA CÔNICA COM PONTA ESFÉRICA ALUMÍNIO	35
REBARBARDORES PARA FIBRA DE VIDRO	36

LIMA ROTATIVA DE METAL DURO

A haste de aço soldada na lima rotativa de metal duro não deve entrar em contato com a peça em trabalho durante a operação de desbaste ou acabamento, pois pode causar superaquecimento na haste, enfraquecendo ou destruindo a solda.

Periodicamente, mergulhe a lima rotativa em lubrificante recomendado para remover o excesso de cavaco no corte.

Tipos de Corte



SC



DC

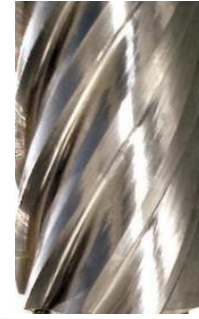



AL

Número de Cortes (+ - 10%)

Ø DA LIMA	CORTE STANDARD	CORTE ALUMÍNIO
1,6 - 1/6	10	-
5/64	10	-
2,4 - 3/32	10	-
3,0 - 1/8	12	-
4,0 - 5/32	15	-
4,8 - 3/16	16	-
6,0 - 1/4	18	-
8,0 - 5/16	20	-
9,5 - 3/8	20	6
10,0	20	-
11,0 - 7/16	21	-
12,0	24	-
12,7 - 1/2	24	8
16,0 - 5/8	30	8
19,0 - 3/4	36	10
25,0	44	12

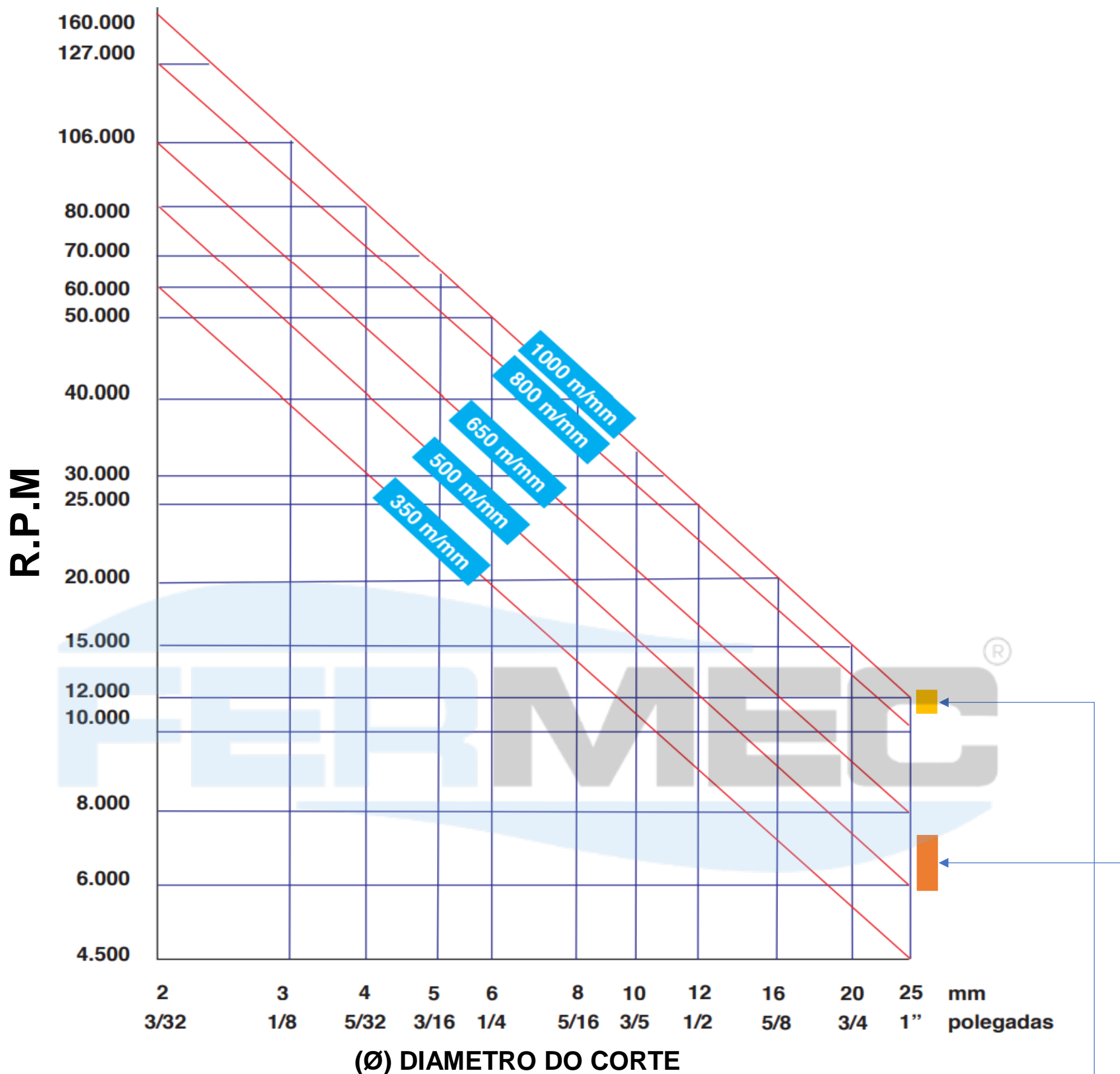
TABELA DE VELOCIDADE DE CORTE



TIPOS DE CORTE	VC m/min.	APLICAÇÃO
ALUMÍNIO  LACUT	800 1000	ALUMÍNIO CORTE GROSSO - Hélice à direita para rápida remoção de materiais não ferrosos e não metálicos. Não ferrosos: alumínio, zinco e magnésio. Não metálicos: plástico e borracha.
STANDARD 	500 650	STANDARD CORTE PARA USO GERAL – Hélice à direita para grandes remoções e bom acabamento. Ferrosos: aço recozido, aço liga. Não ferrosos: alumínio, latão, cobre, bronze e fundidos em geral. Não metálicos: fibras, plásticos, borrachas e grafite. Quebra cavaco - DC Excelente para materiais cortados com oxicorte e outros que produzem cavacos tipo lasca.

LIMAS ROTATIVAS DE METAL DURO

FORMATO DAS LIMAS

SA - Forma cilíndrica sem corte frontal		SH - Forma labareda	
SB - Forma cilíndrica com corte frontal		SJ - Forma cônica 60°	
SC - Forma cilíndrica ponta esférica		SK - Forma cônica 90°	
SD - Forma esférica		SL - Forma cônica com ponta esférica	
SE - Forma oval		SM - Forma cônica	
SF - Forma de árvore com ponta esférica		SN - Forma cônica invertida	
SG - Forma de árvore com ponta aguda			

PADRÃO DE COMPRIMENTOS

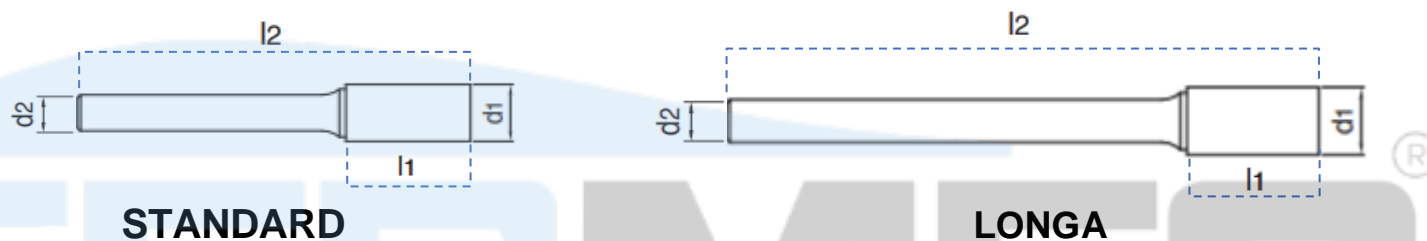

GEOMETRIA DE CORTE

SC Corte simples



DC Corte duplo

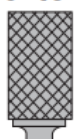

AL Corte para alumínio



SENTIDO DO CORTE

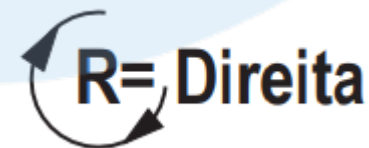

APLICAÇÕES:

SC: Para acabamento em aços em geral e ferros fundidos.

DC: Para operações em aços em geral e ferros fundidos.

AL: Para acabamento em alumínio, bronze, latão, cobre e materiais não ferrosos.

Diâmetro da Haste	Comprimento de Corte	Comprimento Total

Lima Rotativa Cilíndrica

Feitas em Carbetto de Tungstênio, as Limas Rotativas de Metal Duro são itens indispensáveis para diversas indústrias, pois são desenvolvidas com tecnologia de última geração e conferem alto padrão de qualidade na recuperação de soldas (trincas e falhas), operações que demandam remoção de material, desbaste de cordões de solda e rebarbação em geral. O formato da ponta dessa lima rotativa a torna ideal para finalização de contornos.

SA - FORMA CILÍNDRICA SEM CORTE FRONTAL

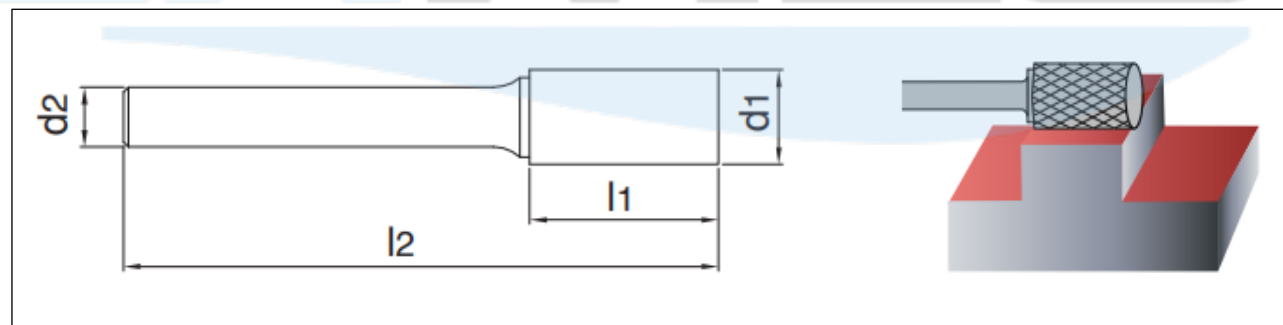
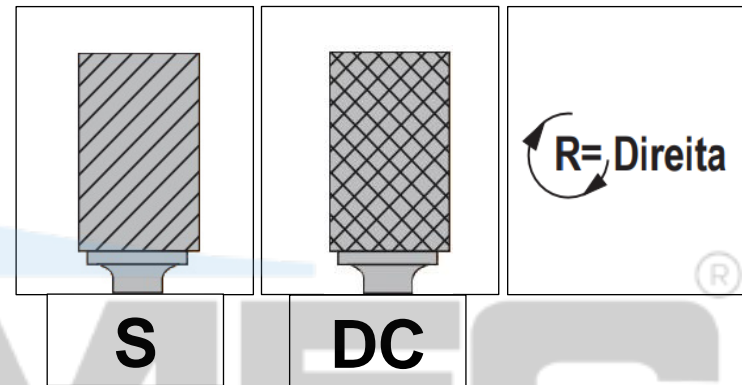

CÓDIGO	d1	d2	l1	l2
SA - 41M	1,5	3	6	38
SA - 42M	2,5	3	11	38
SA - 43M	3	3	14	38
SA - 51M	6,3	3	12,7	50
SA - 1M	6	6	16	50
SA - 2M	8	6	19	63
SA - 3M	9,5	6	19	63
SA - 4M	11	6	25	69
SA - 5M	12,7	6	25	69
*SA - 6M	16	6	25	69
*SA - 7M	19	6	25	69
*SA - 9M	25	6	25	69
SA - 11M	3	6	12	56
SA - 13M	4	6	16	50
SA - 14M	5	6	16	50

SB - FORMA CILÍNDRICA COM CORTE FRONTAL

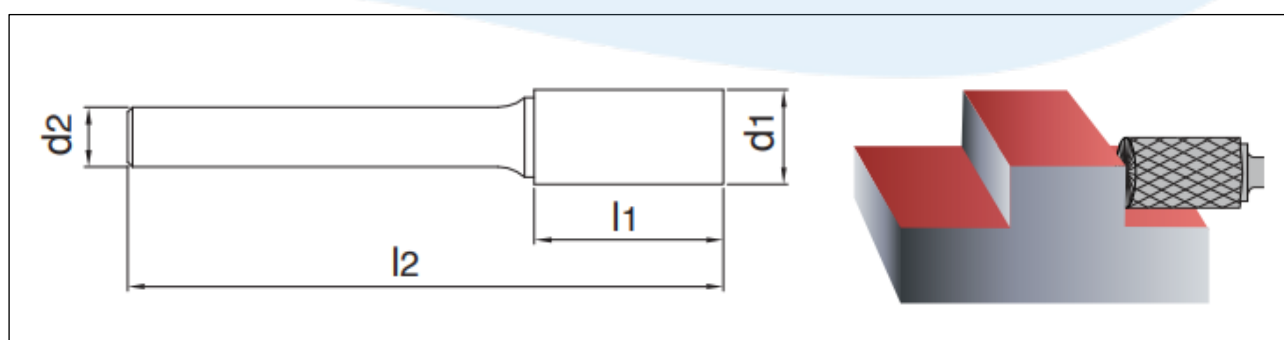
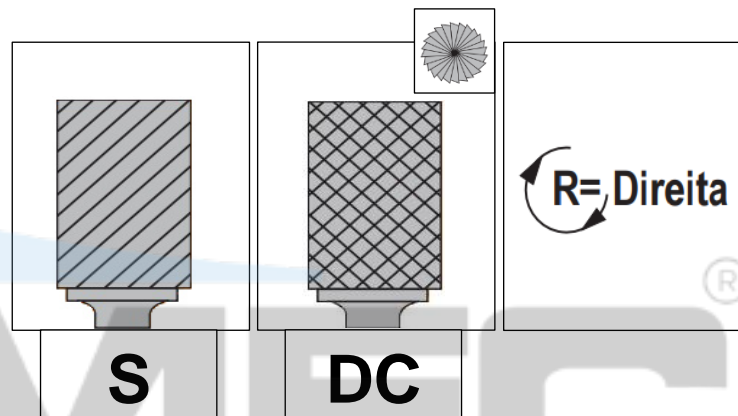

CÓDIGO	d1	d2	l1	l2
SB - 41M	1,5	3	6	38
SB - 41ML3	1,5	3	6	75
SB - 42M	2,5	3	11	38
SB - 42ML3	2,5	3	11	75
SB - 43M	3	3	14	38
SB - 43ML3	3	3	14	75
SB - 51M	6,3	3	4,7	43
SB - 1M	6	6	16	50
SB - 2M	8	6	19	63
SB - 3M	9,5	6	19	63
SB - 4M	11	6	25	69
SB - 5M	12,7	6	25	69
*SB - 6M	16	6	25	69
*SB - 7M	19	6	25	69
*SB - 9M	25	6	25	69
SB - 11M	3	6	12	56
SB - 13M	4	6	16	50
SB - 14M	5	6	16	50

SC - FORMA CILÍNDRICA PONTA ESFÉRICA

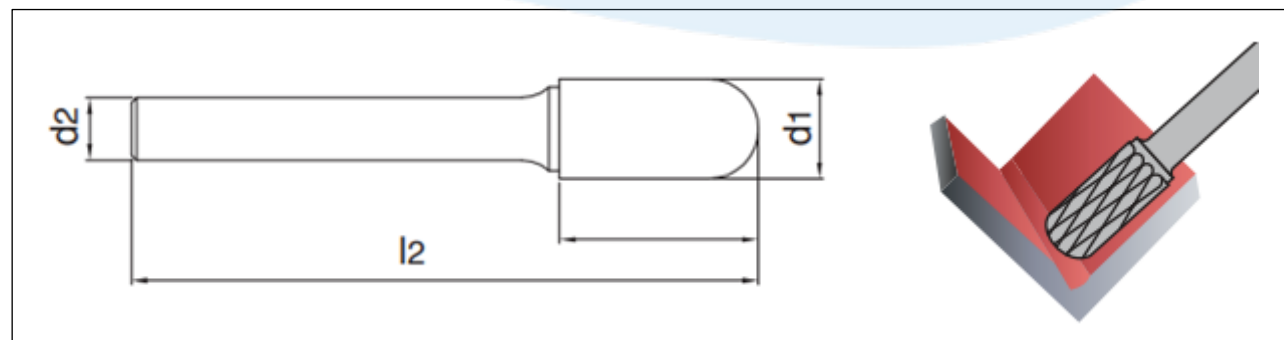
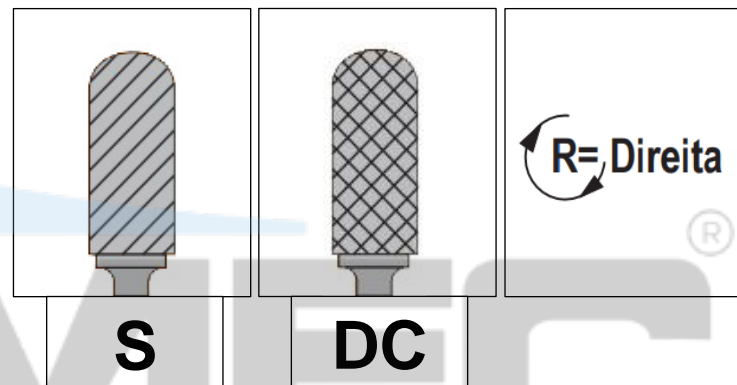

CÓDIGO	d1	d2	l1	l2
SC - 41M	1,5	3	6	75
SC - 42M	2,5	3	11	38
SC - 51M	6,3	3	12,7	50
SC - 1M	6	6	16	50
SC - 2M	8	6	19	63
SC - 3M	9,5	6	19	63
SC - 4M	11	6	25	69
SC - 5M	12,7	6	25	69
*SC - 6M	16	6	25	69
*SC - 7M	19	6	25	69
*SC - 9M	25	6	25	69
SC - 11M	3	6	12	56
SC - 13M	4	6	16	50
SC - 14M	5	6	16	50

SD - FORMA ESFÉRICA

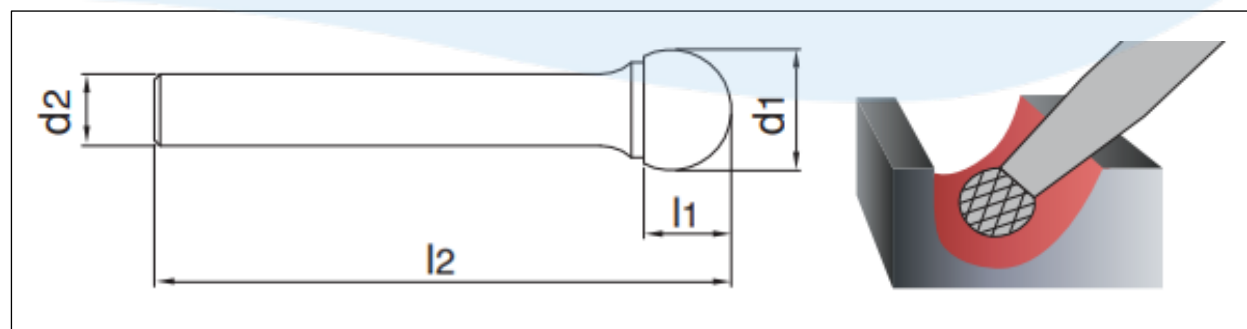
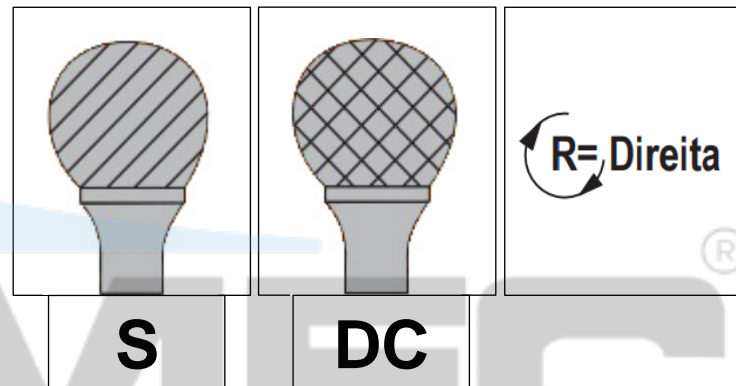
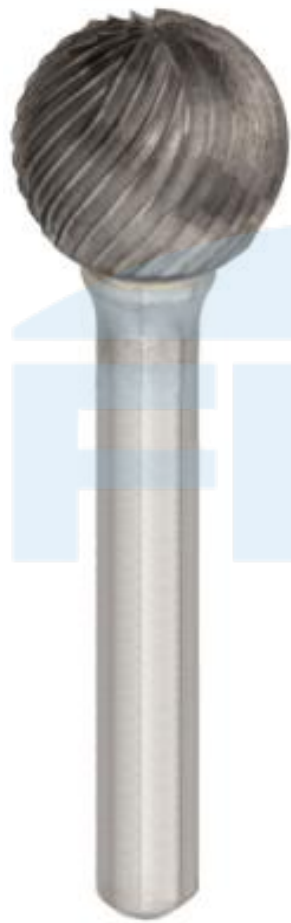

CÓDIGO	d1	d2	l1	l2
SD - 41M	1,5	3	6	75
SD - 42M	2,5	3	11	38
SD - 51M	6,3	3	5	44
SD - 1M	6	6	5	50
SD - 2M	8	6	6,4	50
SD - 3M	9,5	6	8	52
SD - 4M	11	6	9,5	54
SD - 5M	12,7	6	11	55
*SD - 6M	16	6	14	58
*SD - 7M	19	6	16	62
*SD - 9M	25	6	21	72
SD - 11M	3	6	2,5	50
SD - 14M	5	6	4	50

SE - FORMA OVAL

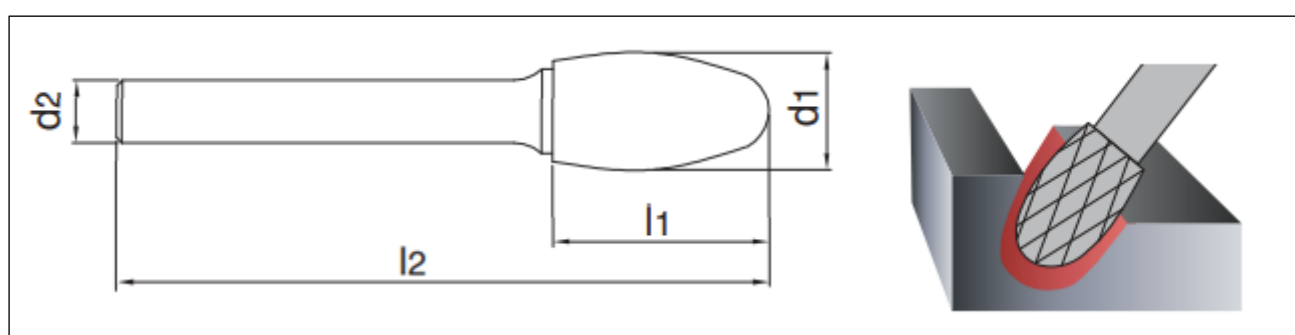
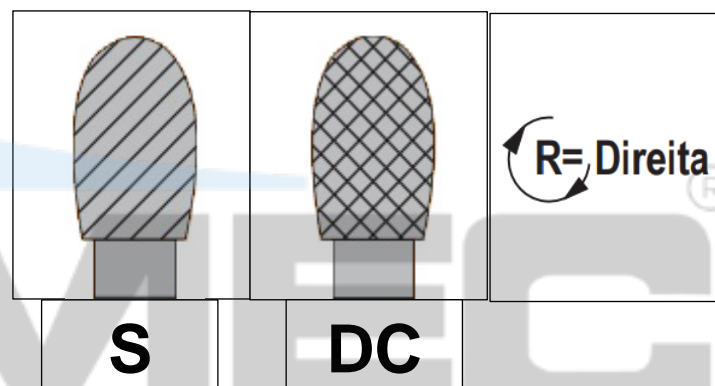

CÓDIGO	d1	d2	l1	l2
SE - 41M	1,5	3	6	38
SE - 51M	6,3	3	9,5	47
SE - 1M	6	6	9,5	50
SE - 3M	9,5	6	16	60
SE - 5M	12,7	6	22	66
*SE - 6M	16	6	25	69
*SE - 7M	19	6	25	69

SF - FORMA DE ÁRVORE COM PONTA ESFÉRICA

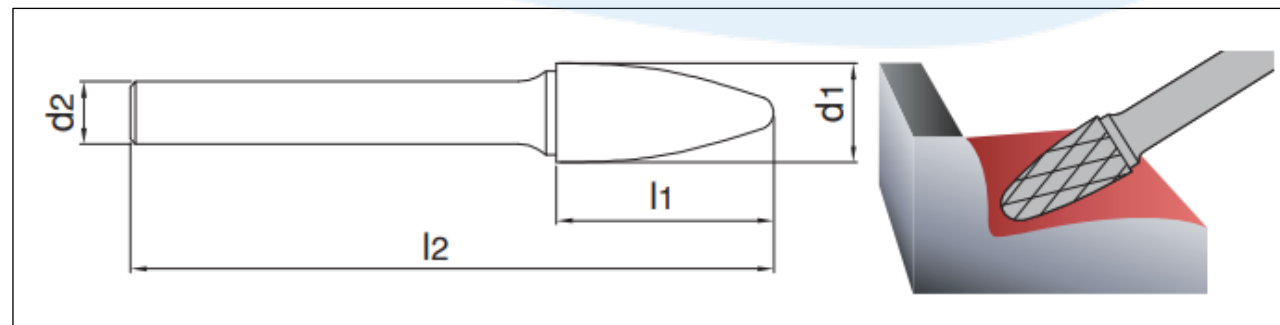
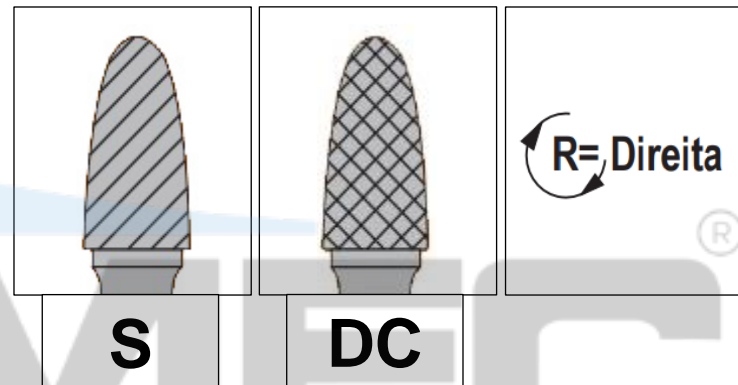

CÓDIGO	d1	d2	l1	l2
SF - 41M	1,5	3	6	75
SF - 42M	2,5	3	11	38
SF - 51M	6,3	3	12,7	50
SF - 1M	6	6	16	50
SF - 3M	9,5	6	19	63
SF - 4M	11	6	25	69
SF - 5M	12,7	6	25	69
SF - 6M	16	6	25	69
*SF - 7M	19	6	25	69
SF - 11M	3	6	12,7	56
SF - 13M	12,7	6	19	63
*SF - 14M	19	6	32	76
*SF - 15M	19	6	38	82

SG - FORMA DE ÁRVORE COM PONTA AGUDA

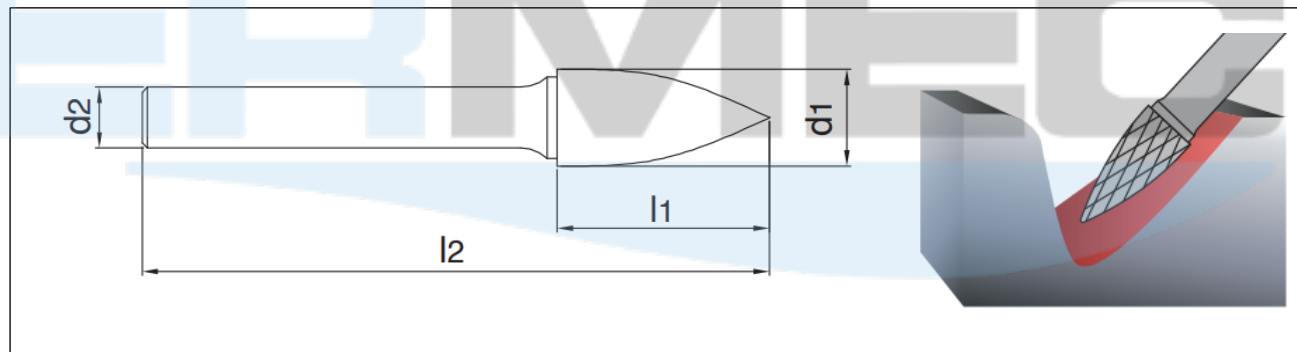
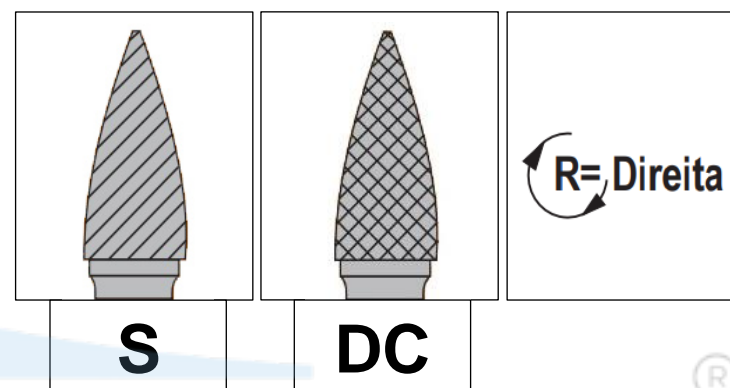

CÓDIGO	d1	d2	l1	l2
SG - 41M	1,5	3	6	38
SG - 43M	1,5	3	6	75
SG - 44M	2,5	3	11	38
SG - 51M	6,3	3	12,7	50
SG - 1M	6	6	16	50
SG - 2M	8	6	19	63
SG - 3M	9,5	6	19	63
SG - 5M	12,7	6	25	69
SG - 6M	16	6	25	69
SG - 7M	19	6	25	69
SG - 13M	12,7	6	19	63
SG - 15M	19	6	38	82

SH - FORMA DE LABAREDA

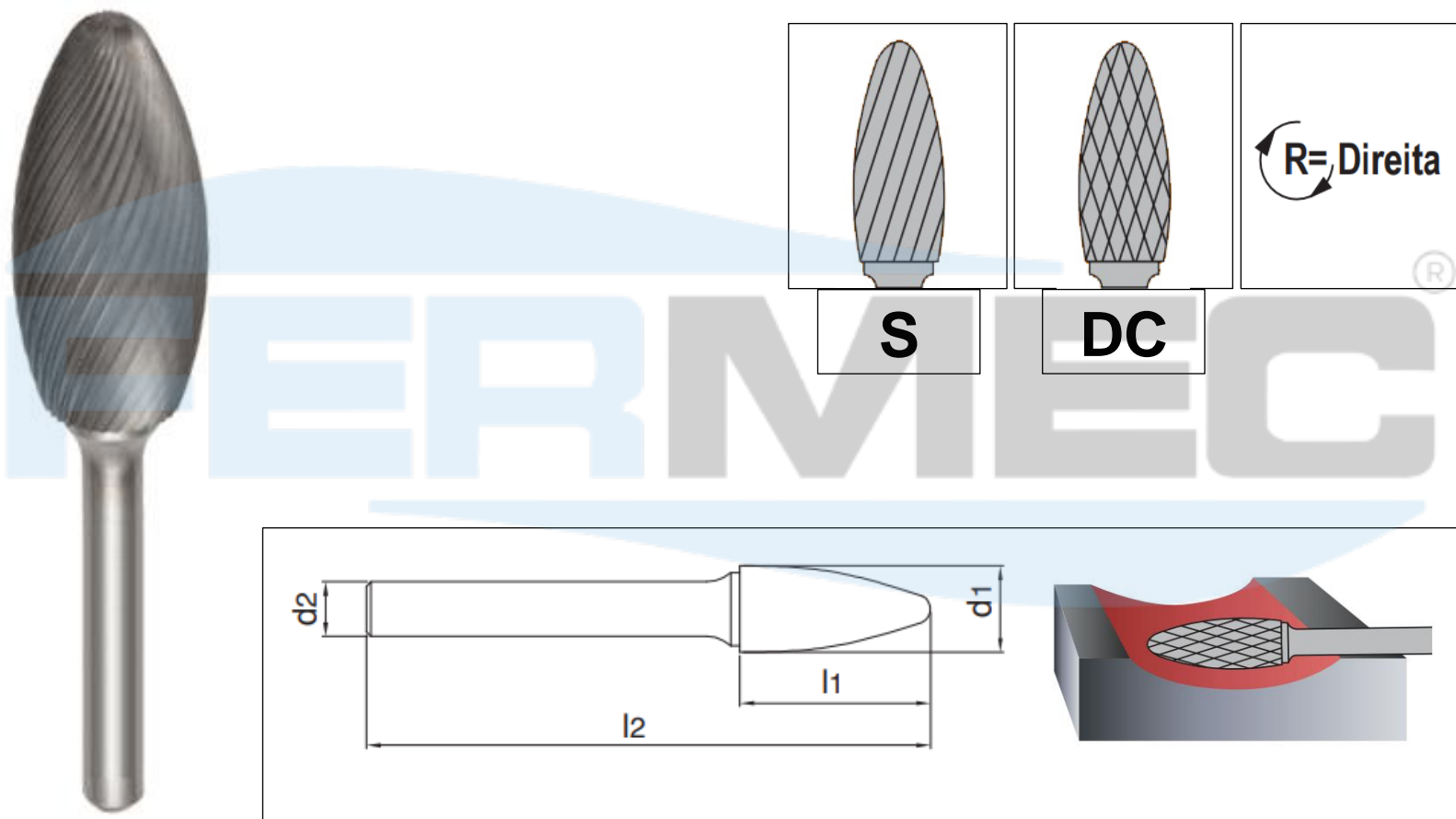

CÓDIGO	d1	d2	l1	l2
SH - 41M	1,5	3	6	38
SH - 4M	8	6	19	63
SH - 5M	12,7	6	32	76
SH - 6M	16	6	36	80
SH - 7M	19	6	41	85

SJ - FORMA CÔNICA 60°

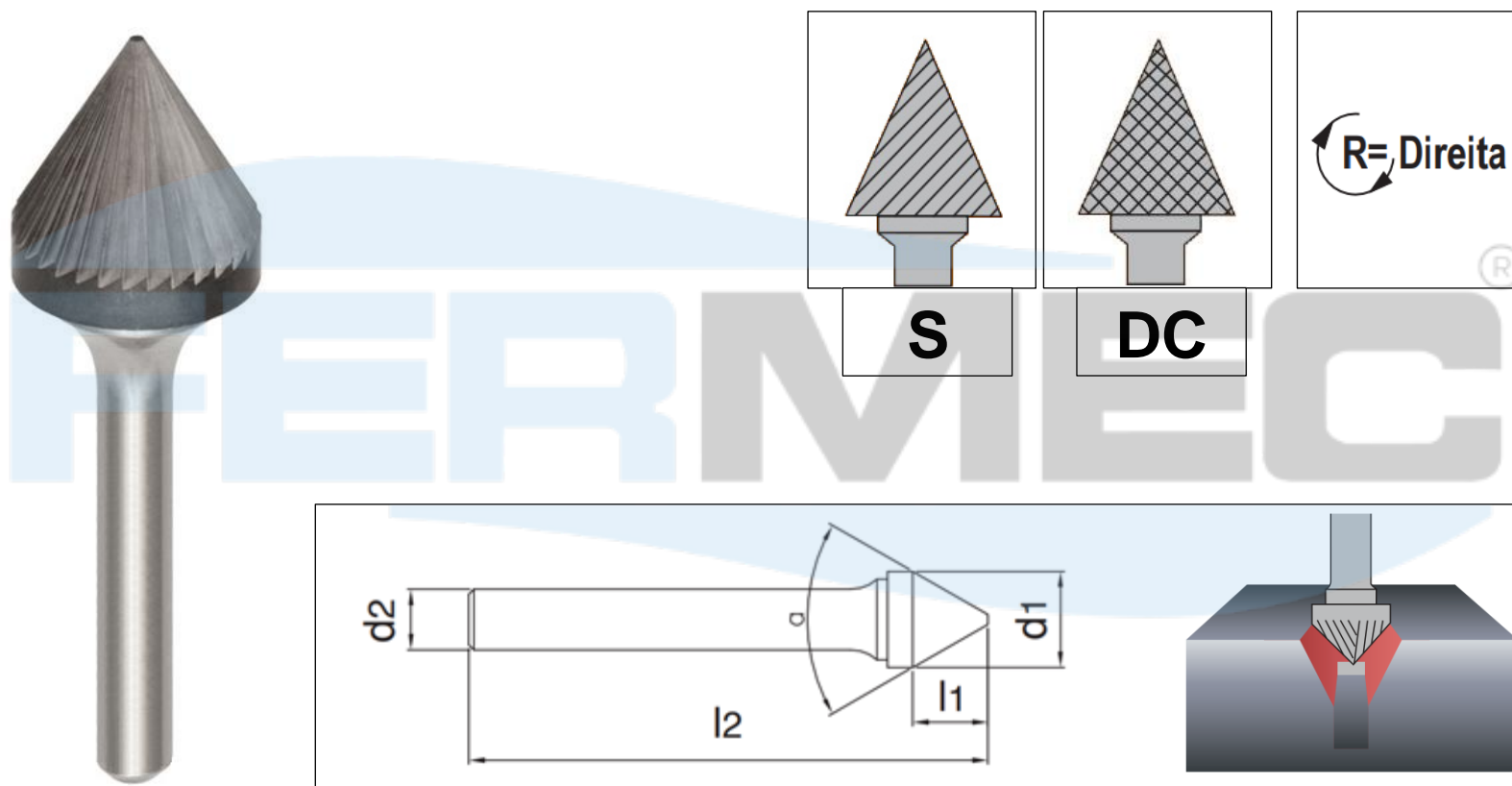

CÓDIGO	d1	d2	l1	l2
SJ - 42M	1,5	3	6	75
SJ - 1M	6	6	4	50
SJ - 3M	9,5	6	8	55
SJ - 5M	12,7	6	11	58
*SJ - 6M	16	6	14,5	61
*SJ - 7M	19	6	17,5	65
*SJ - 9M	25	6	24,5	68

SK - FORMA CÔNICA 90°

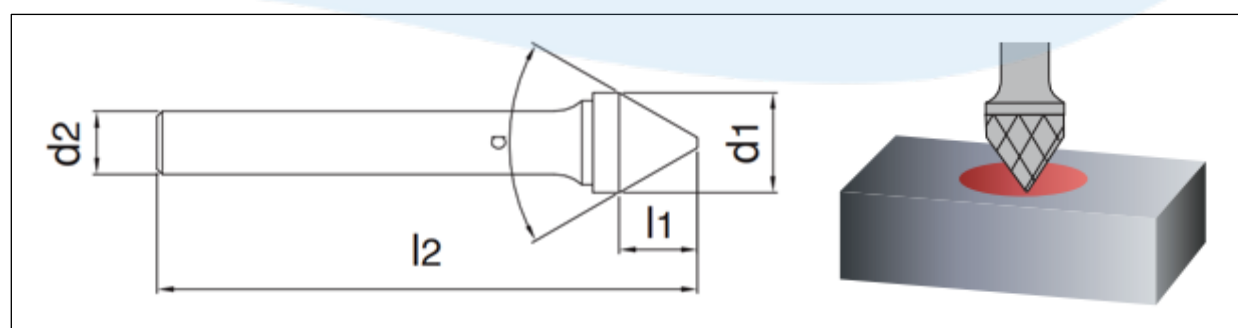
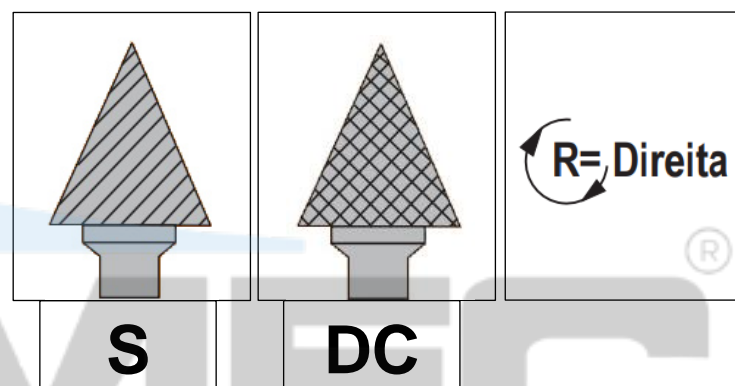

CÓDIGO	d1	d2	l1	l2
SK - 42M	1,5	3	6	75
SK - 1M	6	6	3	50
SK - 3M	9,5	6	4,7	52
SK - 5M	12,7	6	6,3	54
*SK - 6M	16	6	8	57
*SK - 7M	19	6	9,5	58
*SK - 9M	25	6	12,7	60

SL - FORMA CÔNICA COM PONTA ESFÉRICA

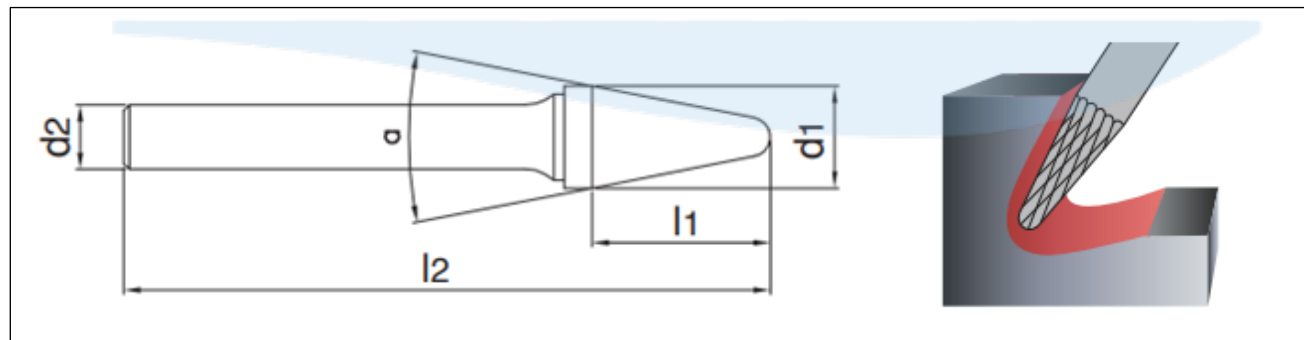
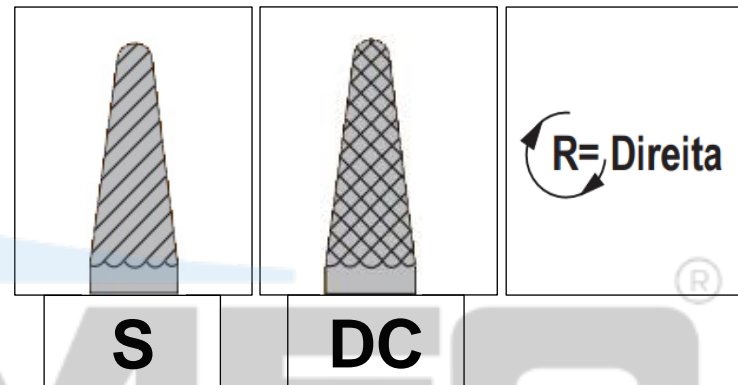

CÓDIGO	d1	d2	l1	l2	a°
SL - 41M	1,5	3	6	75	-
SL - 42M	2,5	3	11	38	-
SL - 1M	6	6	16	50	14°
SL - 2M	8	6	22	69	14°
SL - 3M	9,5	6	27	74	14°
SL - 4M	12,7	6	28	76	14°
*SL - 5M	16	6	30	77	14°
*SL - 7M	19	6	38	85	14°

SM - FORMA CÔNICA

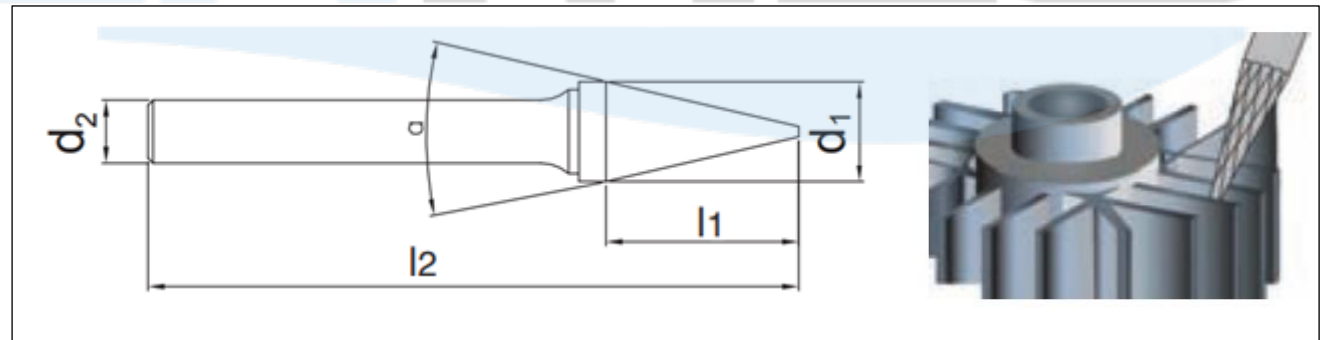
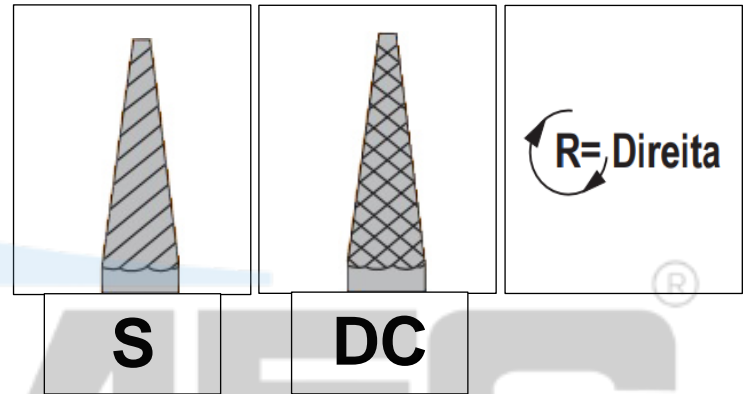

CÓDIGO	d1	d2	l1	l2	a°
SM - 41	1,5	3	6	75	-
SM - 42M	2,5	3	11	38	-
SM - 42ML3	2,5	3	11	75	-
SM - 43M	2,5	3	11	38	-
SM - 51M	6,3	3	12,7	54	22°
SM - 1M	6	6	12,7	50	22°
SM - 2M	6	6	19	50	14°
SM - 3M	6	6	25	50	10°
SM - 4M	9,5	6	16	63	28°
*SM - 5M	12,7	6	22	69	28°
*SM - 6M	16	6	25	73	31°



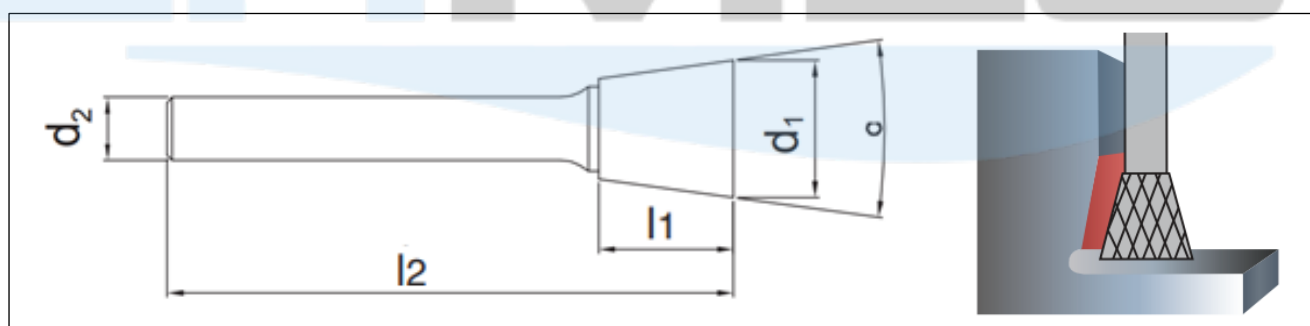
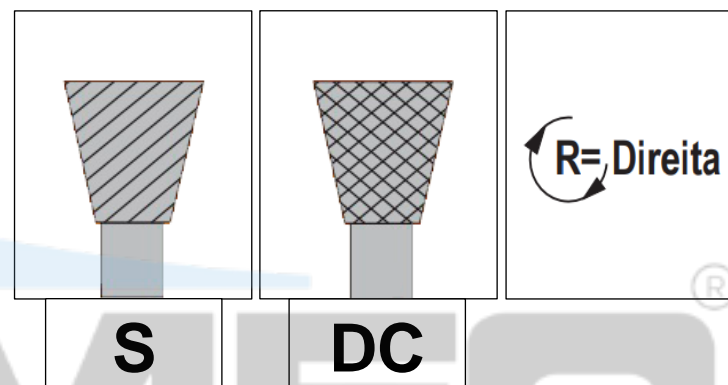



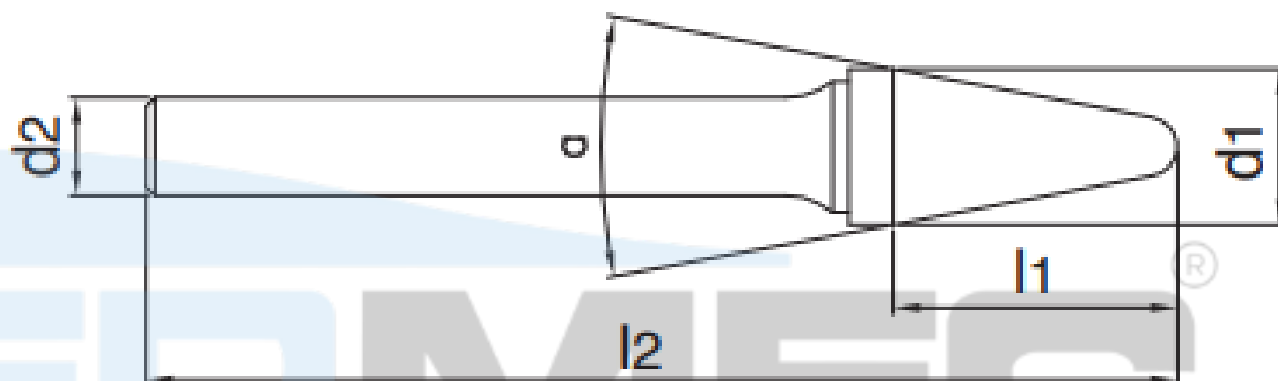

SN - FORMA CÔNICA INVERTIDA



CÓDIGO	d1	d2	l1	l2	a°
SN - 42M	2,5	3	11	38	-
SN - 42M	2,5	3	11	38	-
SN - 51M	6,3	3	6	44	10°
SN - 1M	6	6	8	50	10°
SN - 2M	9,5	6	9,5	53	13°
SN - 4M	12,7	6	12,7	57	28°
*SN - 6M	16	6	19	63	18°
*SN - 7M	19	6	16	60	30°



LIMAS

	CÓDIGO	d1	d2	l1	l2	a
	SA - 51M	6,3	3	12,7	50	-
	SB - 51M	6,3	3	4,7	43	-
	SC - 51M	6,3	3	12,7	50	-
	SD - 51M	6,3	3	5	44	-
	SE - 51M	6,3	3	9,5	47	-
	SF - 51M	6,3	3	12,7	50	-
	SG - 51M	6,3	3	12,7	50	-
	SM - 51M	6,3	3	12,7	54	22°
	SN - 51M	6,3	3	6	44	10°

SA - FORMA CILÍNDRICA SEM CORTE FRONTAL LONGA

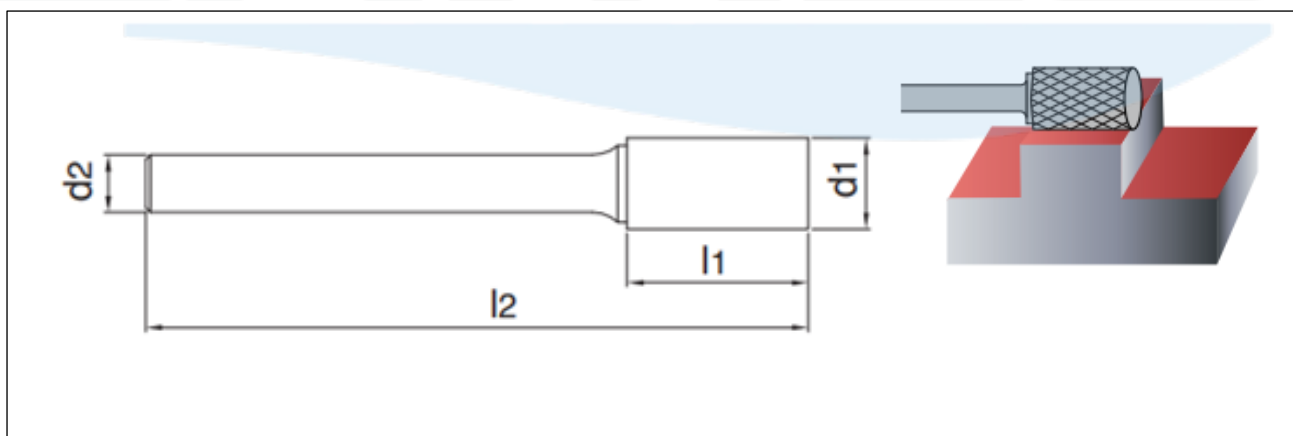
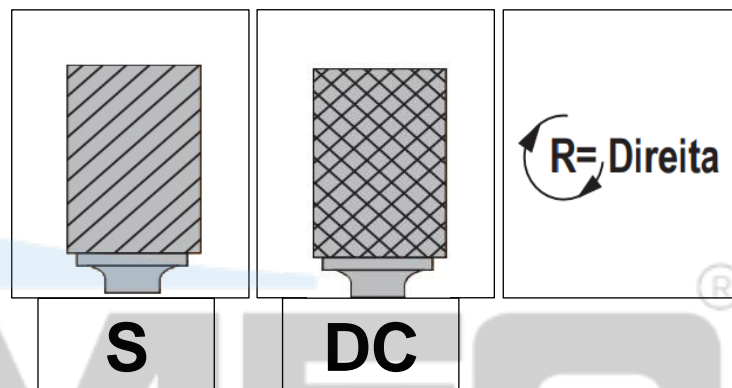

CÓDIGO	d1	d2	l1	l2
SA - 41ML3	1,5	3	6	75
SA - 42ML3	2,5	3	11	75
SA - 43ML3	3	3	14	75
SA - 1ML6	6	6	12,7	162
SA - 3ML6	9,5	6	19	169
SA - 5ML6	12,7	6	25	175

SC - FORMA CILÍNDRICA PONTA ESFÉRICA LONGA

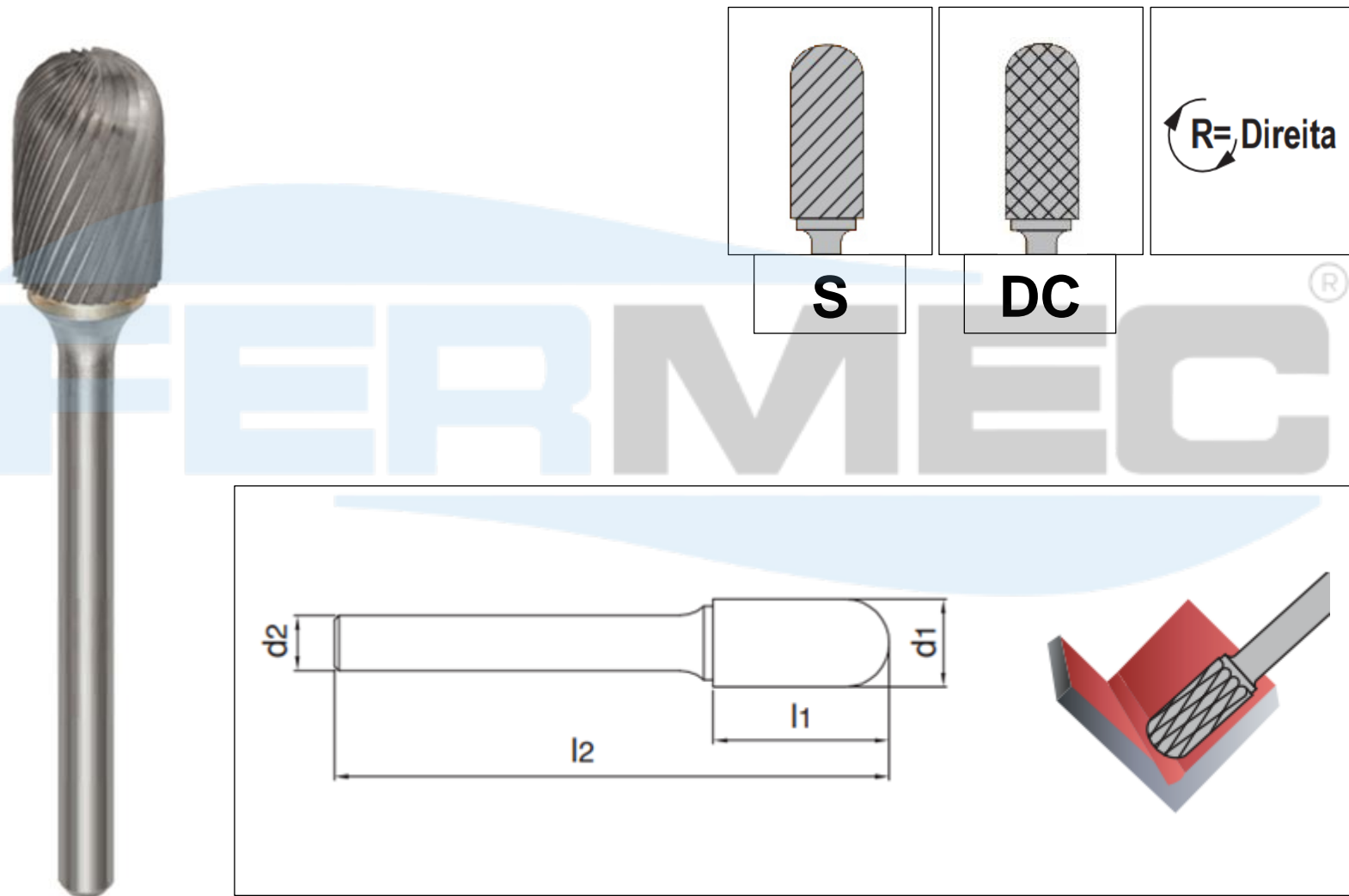

CÓDIGO	d1	d2	l1	l2
SC - 42ML3	2,5	3	11	75
SC - 1ML6	6	6	12,7	162
SC - 3ML6	9,5	6	19	169
SC - 5ML6	12,7	6	25	175

SD - FORMA ESFÉRICA LONGA

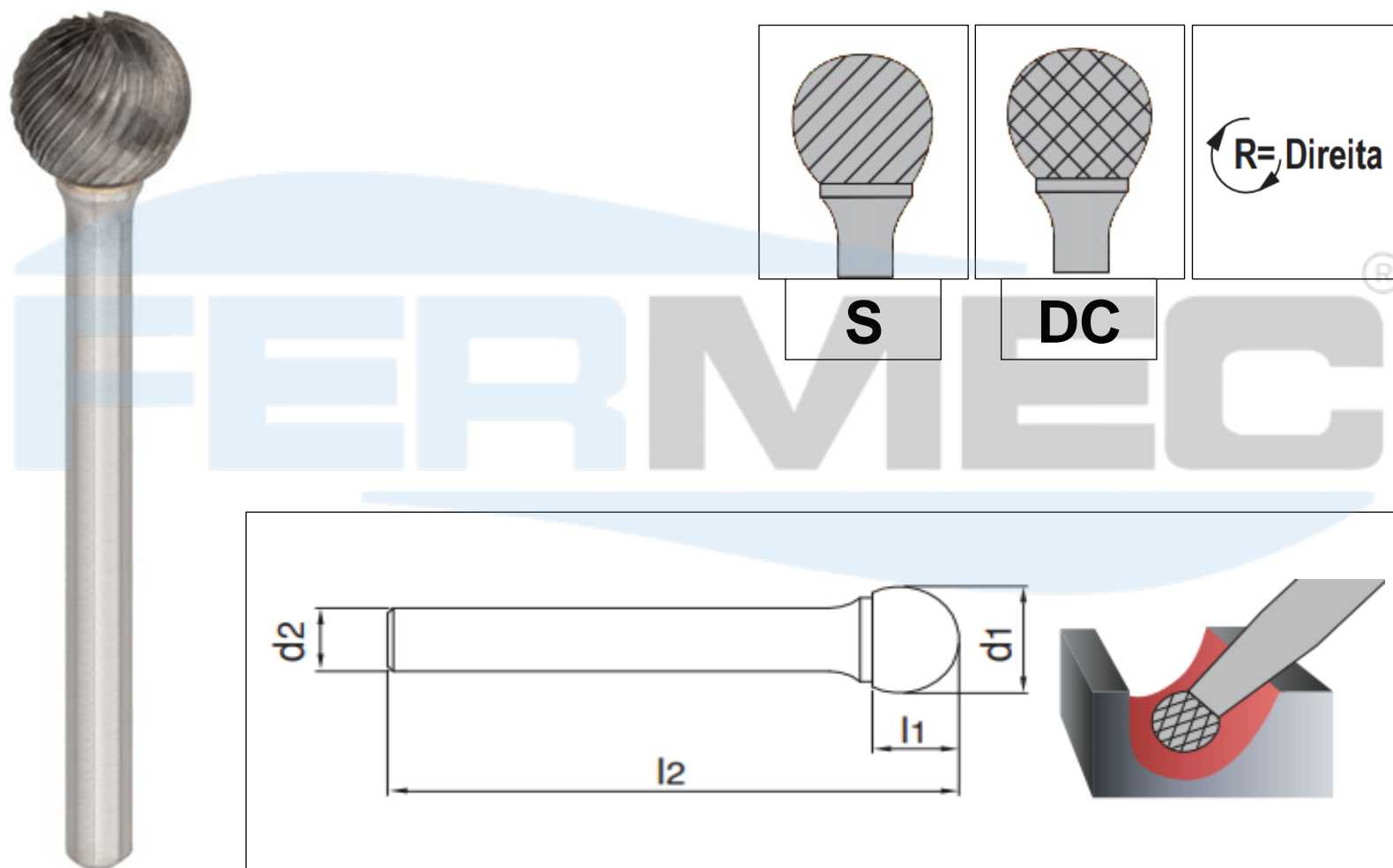

CÓDIGO	d1	d2	l1	l2
SD - 42ML3	2,5	3	11	75
SD - 1ML6	6	6	5	155
SD - 3ML6	9,5	6	8	158
SD - 5ML6	12,7	6	11	161

SE - FORMA OVAL LONGA

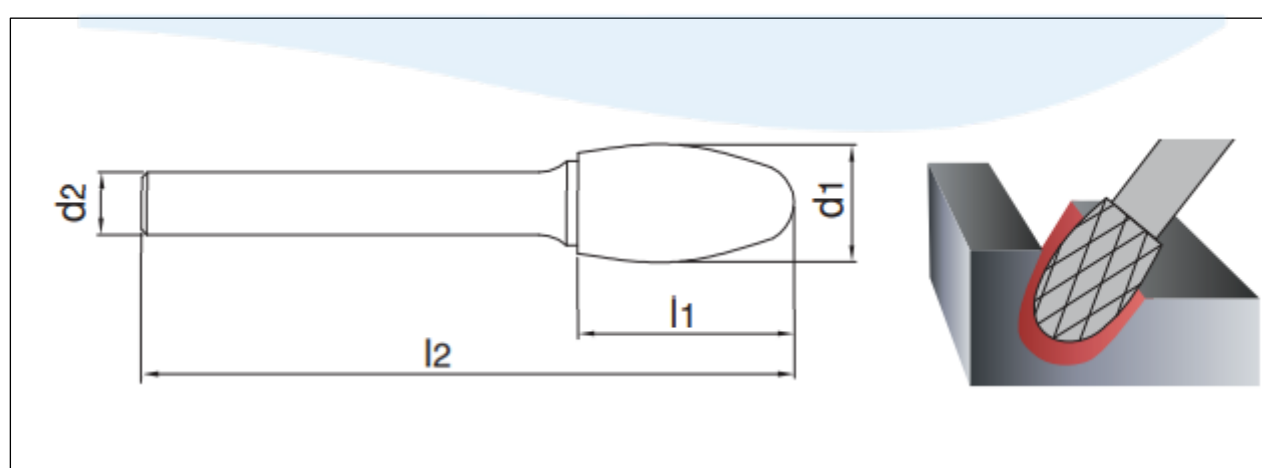
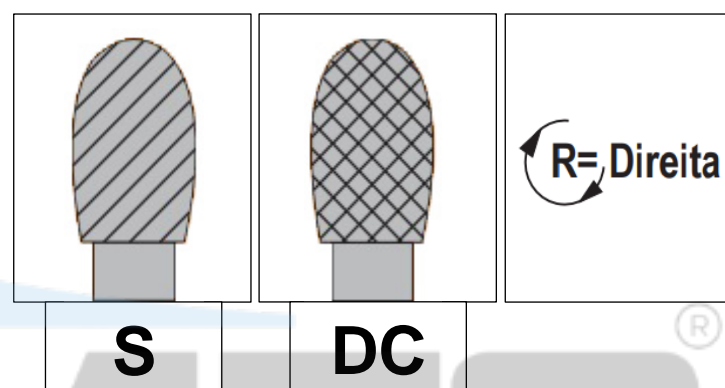

CÓDIGO	d1	d2	l1	l2
SE - 1ML6	6	6	9,5	160
SE - 3ML6	9,5	6	16	166
SE - 5ML6	12,7	6	22	172

SF - FORMA DE ÁRVORE COM PONTA ESFÉRICA LONGA

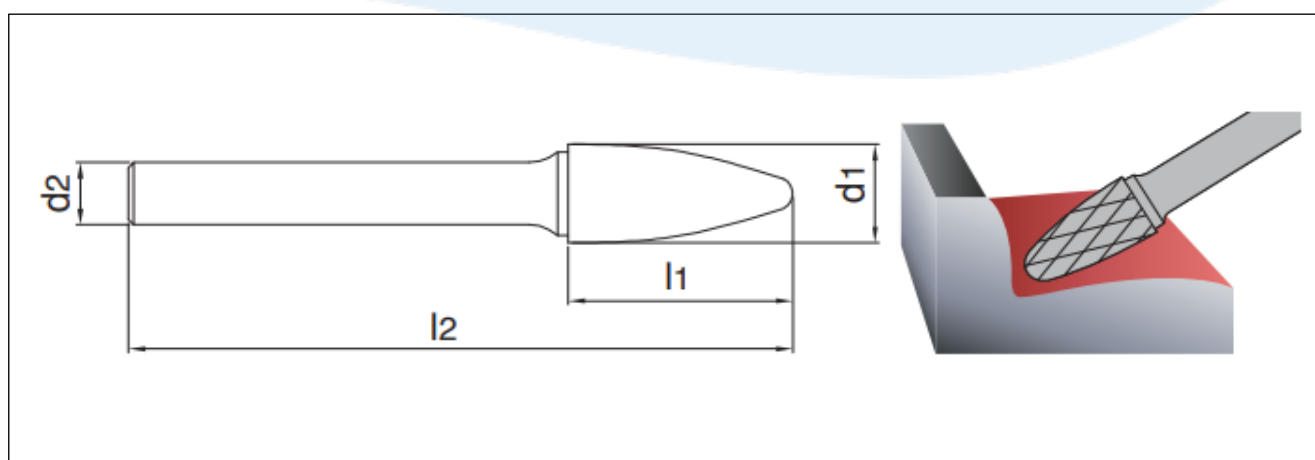
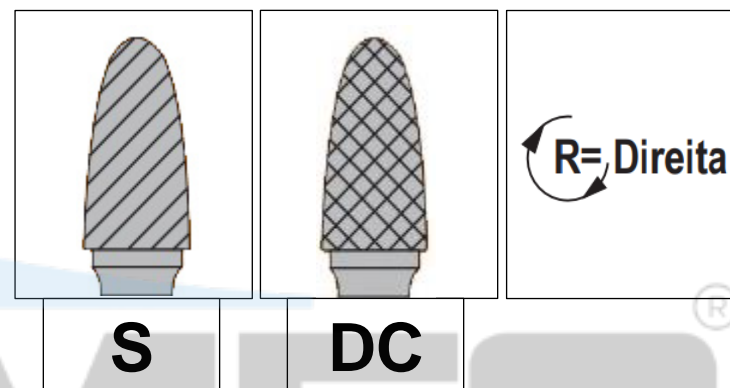
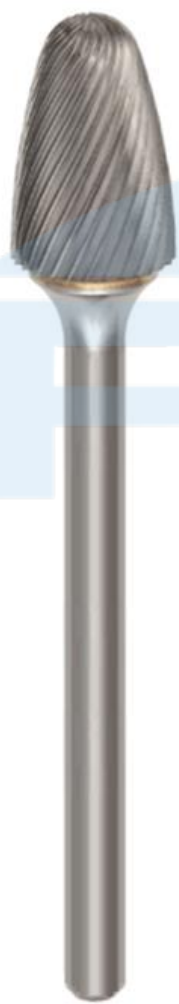

CÓDIGO	d1	d2	l1	l2
SF - 42ML3	2,5	3	11	75
SF - 1ML6	6	6	12,7	163
SF - 3ML6	9,5	6	19	169
SF - 5ML6	12,7	6	25	175

SG - FORMA DE ÁRVORE COM PONTA AGUDA LONGA

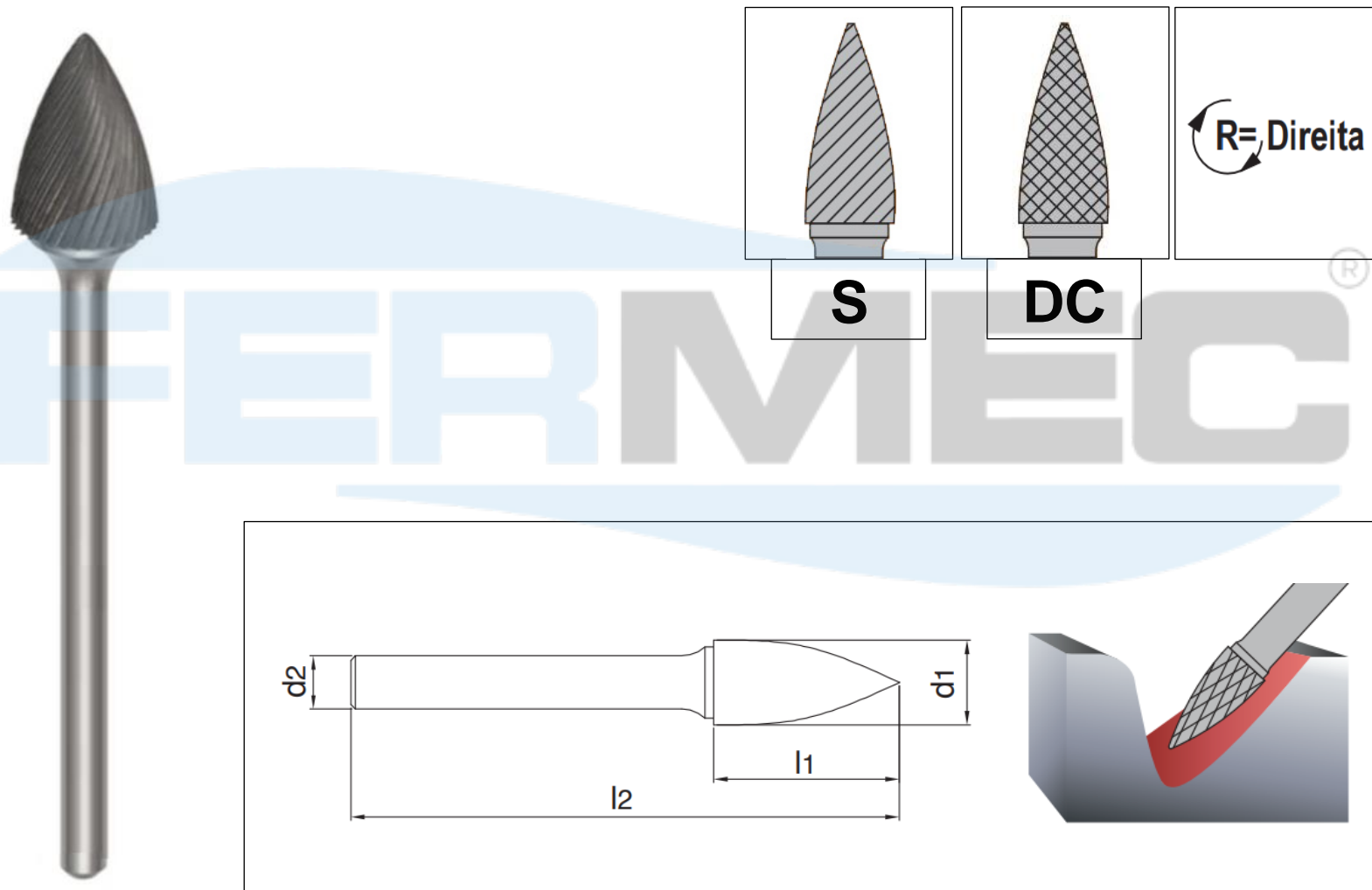

CÓDIGO	d1	d2	l1	l2
SG - 44ML3	2,5	3	11	75
SG - 1ML6	6	6	12,7	163
SG - 3ML6	9,5	6	19	169
SG - 5ML6	12,7	6	25	175

SH - FORMA DE LABAREDA LONGA

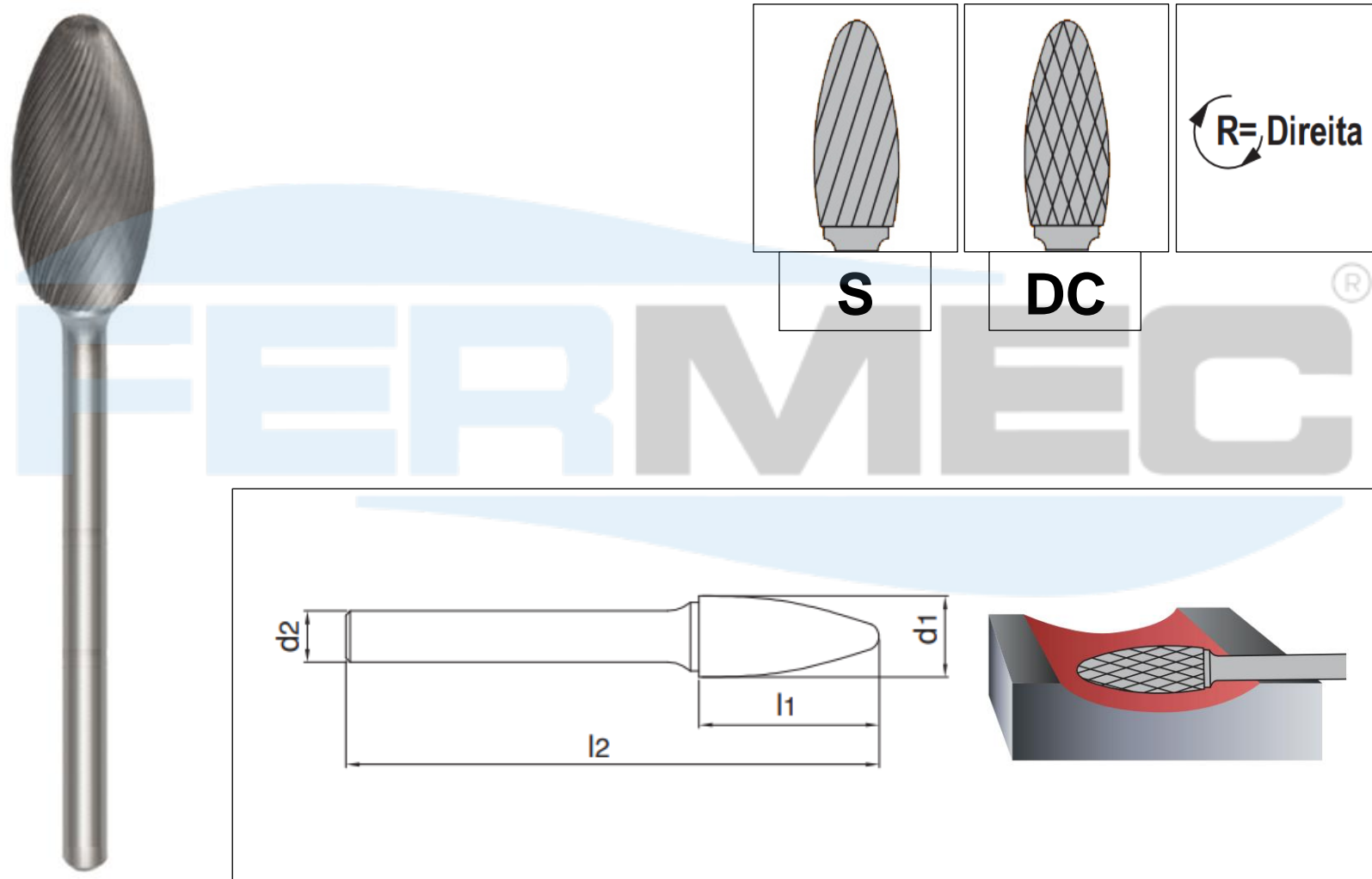

CÓDIGO	d1	d2	l1	l2
SH - 41ML3	1,5	3	6	75
SH - 2ML6	8	6	19	169
SH - 5ML6	12,7	6	32	182

SL - FORMA CÔNICA COM PONTA ESFÉRICA LONGA

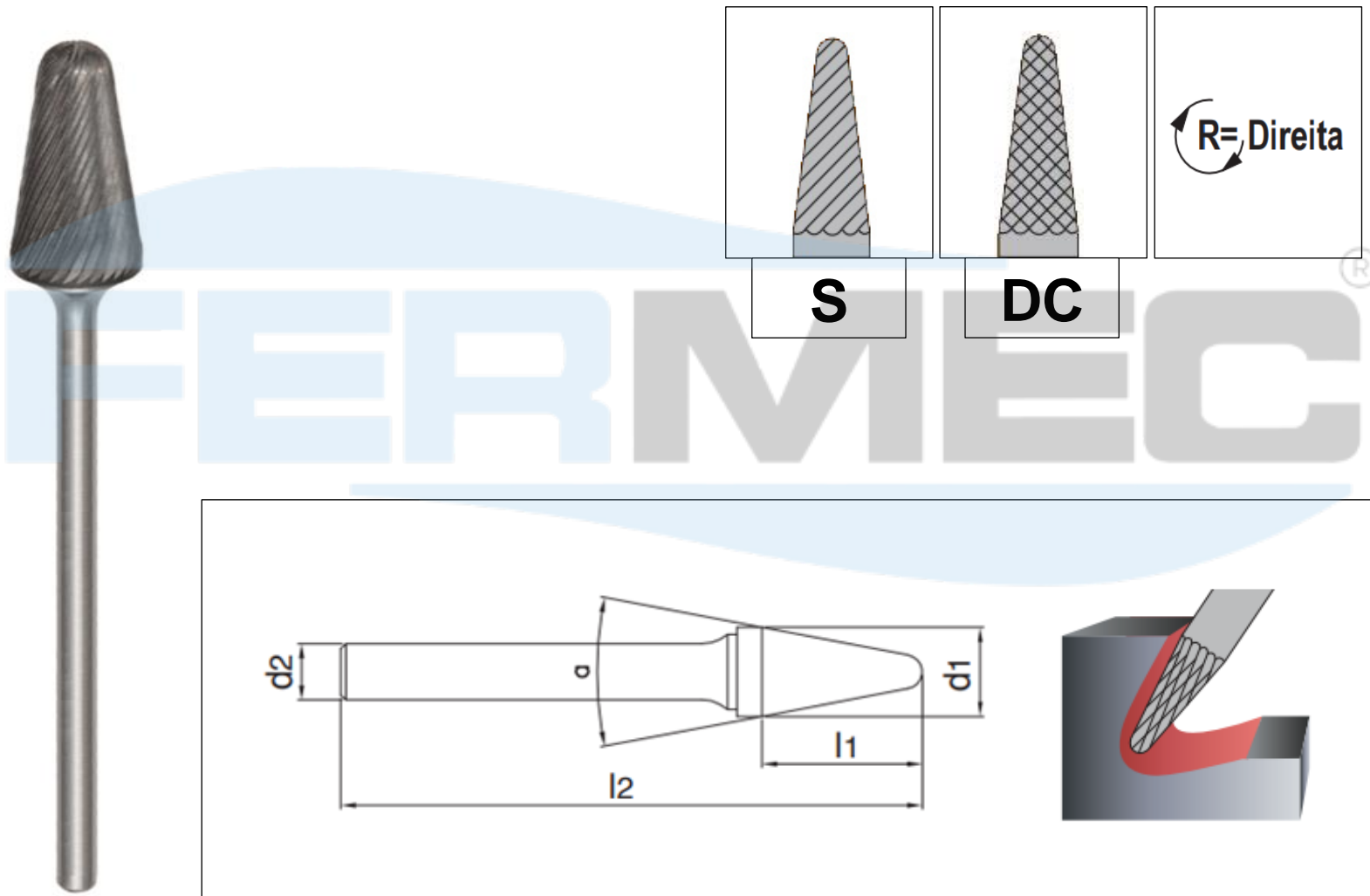

CÓDIGO	d1	d2	l1	l2
SL - 42ML3	2,5	3	11	75
SL - 1ML6	6	6	16	166
SL - 3ML6	9,5	6	27	177
SL - 4ML6	12,7	6	28	178

SA - FORMA CILÍNDRICA SEM CORTE FRONTAL ALUMÍNIO

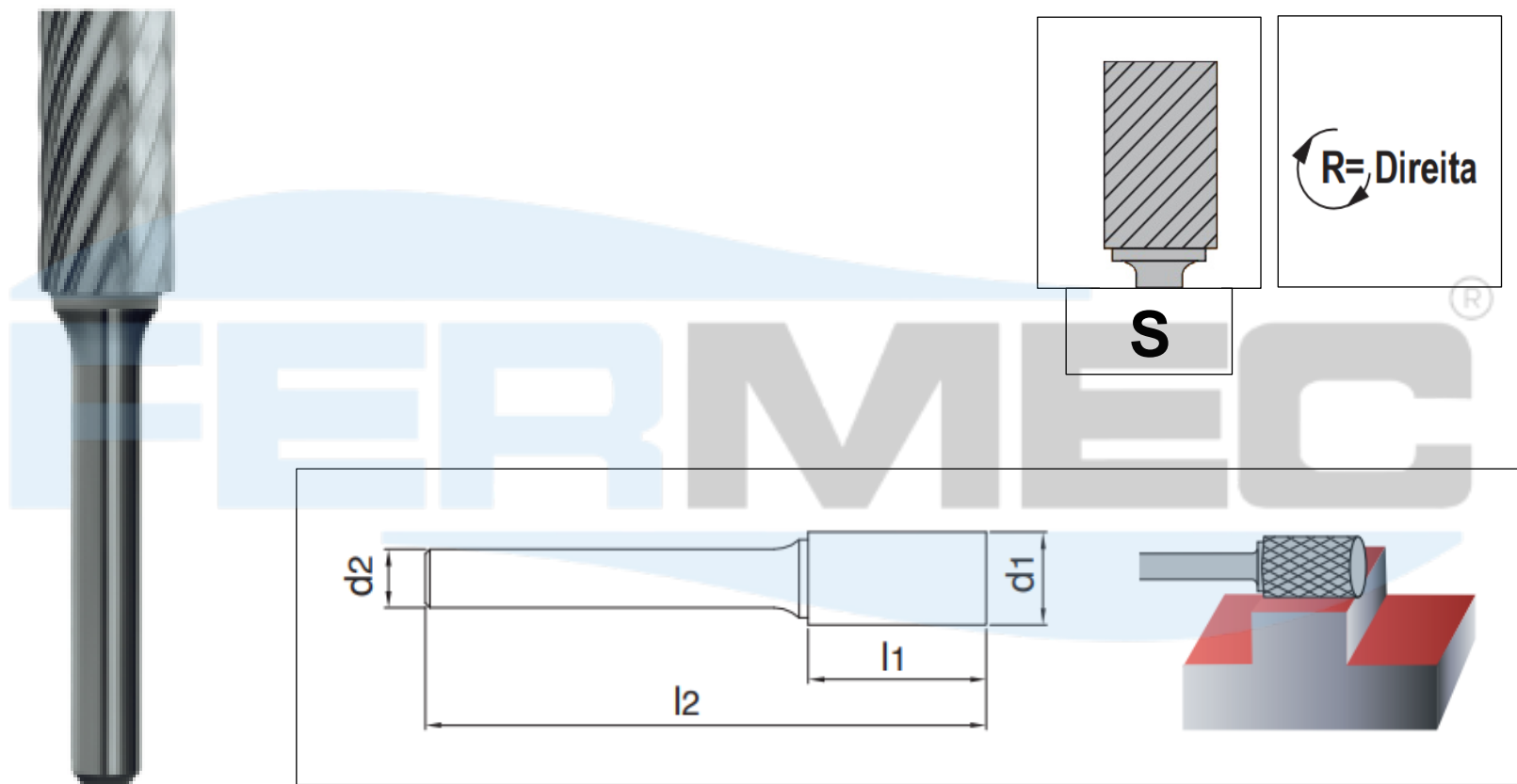

CÓDIGO	d1	d2	l1	l2
SA - 1M ALUM.	6	6	19	50
SA - 3M ALUM.	9,5	6	19	63
SA - 5M ALUM.	12,7	6	25	69
*SA - 6M ALUM.	16	6	25	69
*SA - 7M ALUM.	19	6	25	69

SB - FORMA CILÍNDRICA COM CORTE FRONTAL ALUMÍNIO

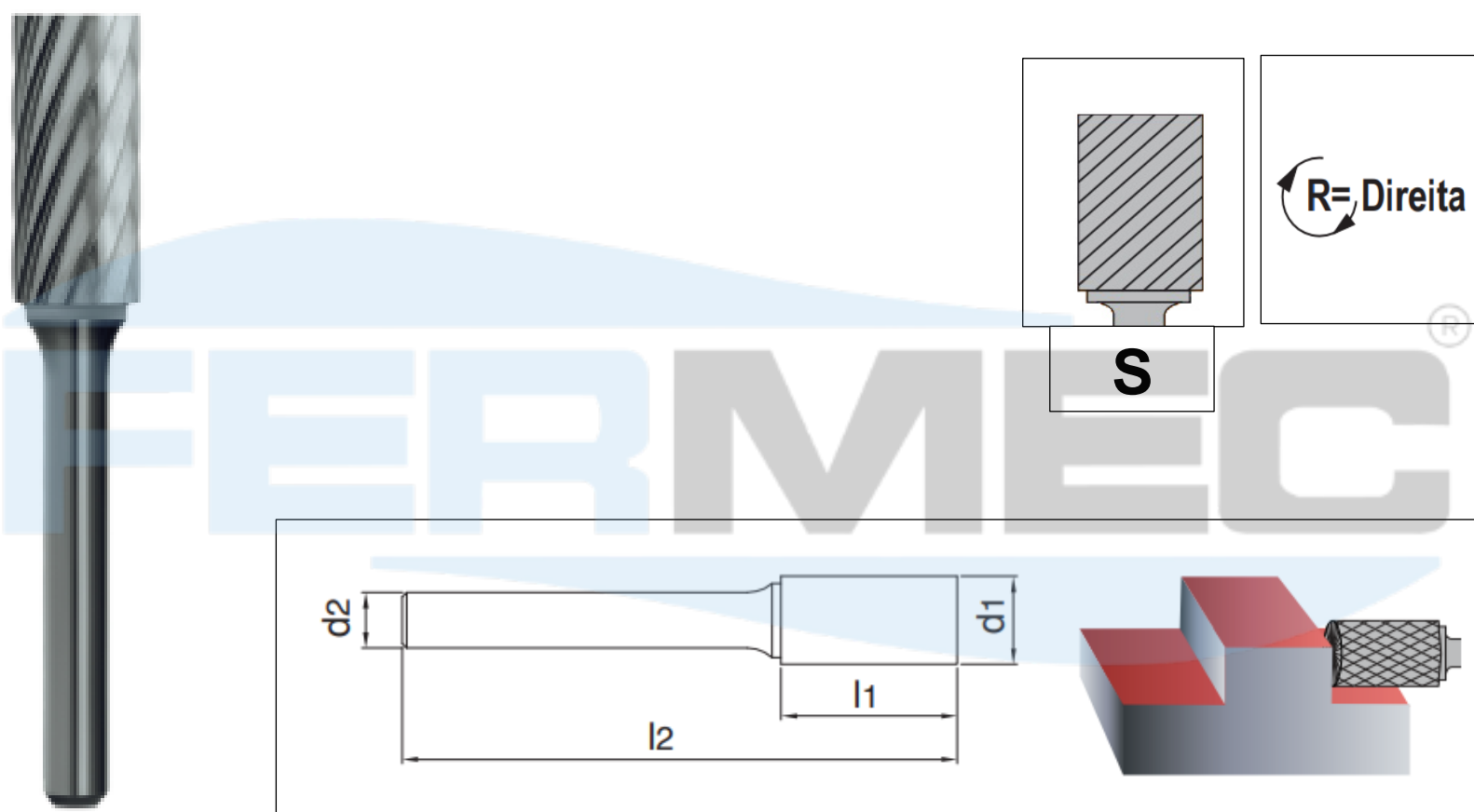

CÓDIGO	d1	d2	l1	l2
SB - 1M ALUM.	6	6	19	50
SB - 3M ALUM.	9,5	6	19	63
SB - 5M ALUM.	12,7	6	25	69
*SB - 6M ALUM.	16	6	25	69
*SB - 7M ALUM.	19	6	25	69

SC - FORMA CILÍNDRICA PONTA ESFÉRICA ALUMÍNIO

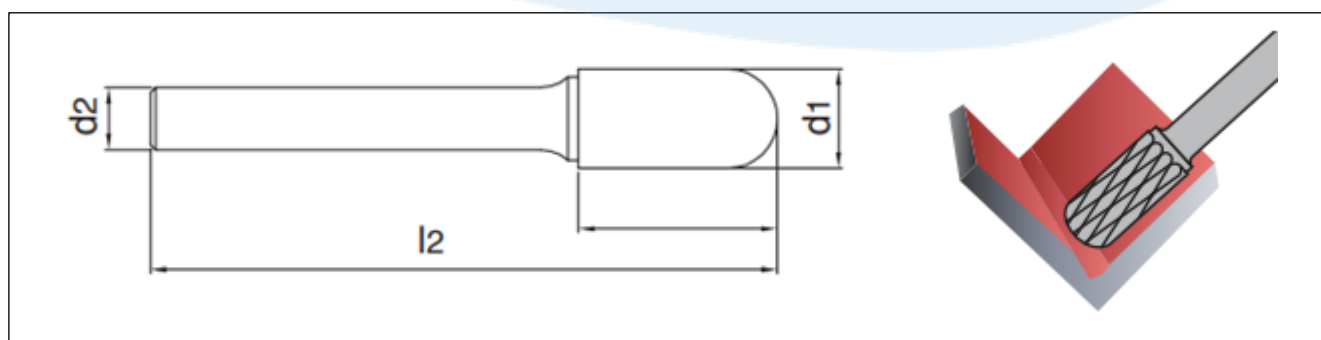
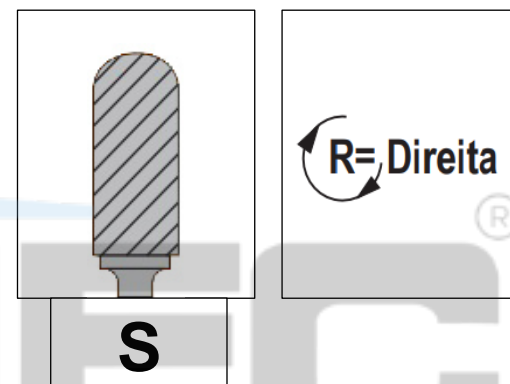

CÓDIGO	d1	d2	l1	l2
SC - 1M ALUM.	6	6	19	50
SC - 3M ALUM.	9,5	6	19	63
SC - 5M ALUM.	12,7	6	25	69
SC - 6M ALUM.	16	6	25	69
*SC - 7M ALUM.	19	6	25	69

SD - FORMA ESFÉRICA ALUMÍNIO

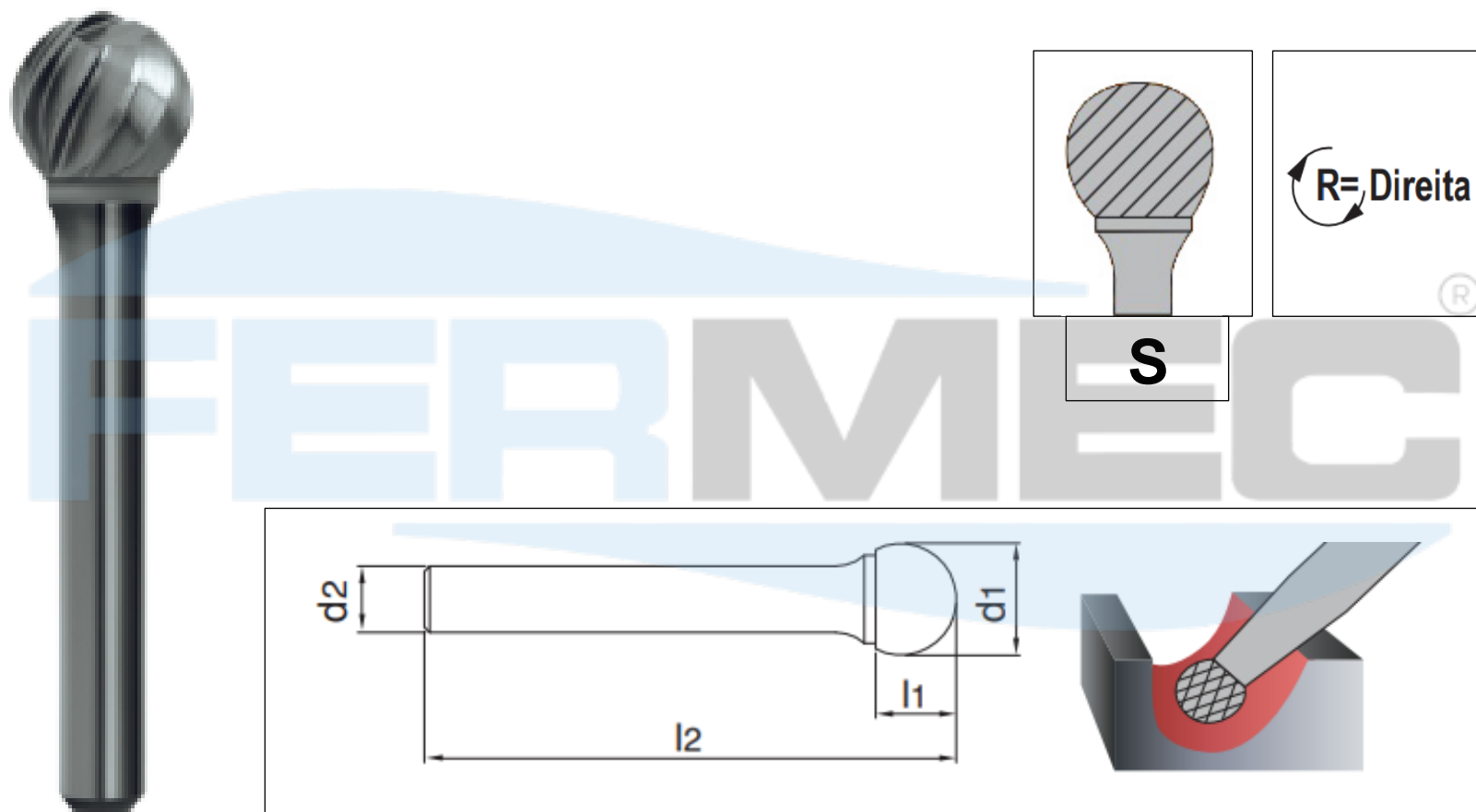

CÓDIGO	d1	d2	l1	l2
SD - 1M ALUM.	6	6	5	50
SD - 3M ALUM.	9,5	6	8	52
SD - 5M ALUM.	12,7	6	11	55
*SD - 6M ALUM.	16	6	14	58
*SD - 7M ALUM.	19	6	16	62

SE - FORMA OVAL ALUMÍNIO

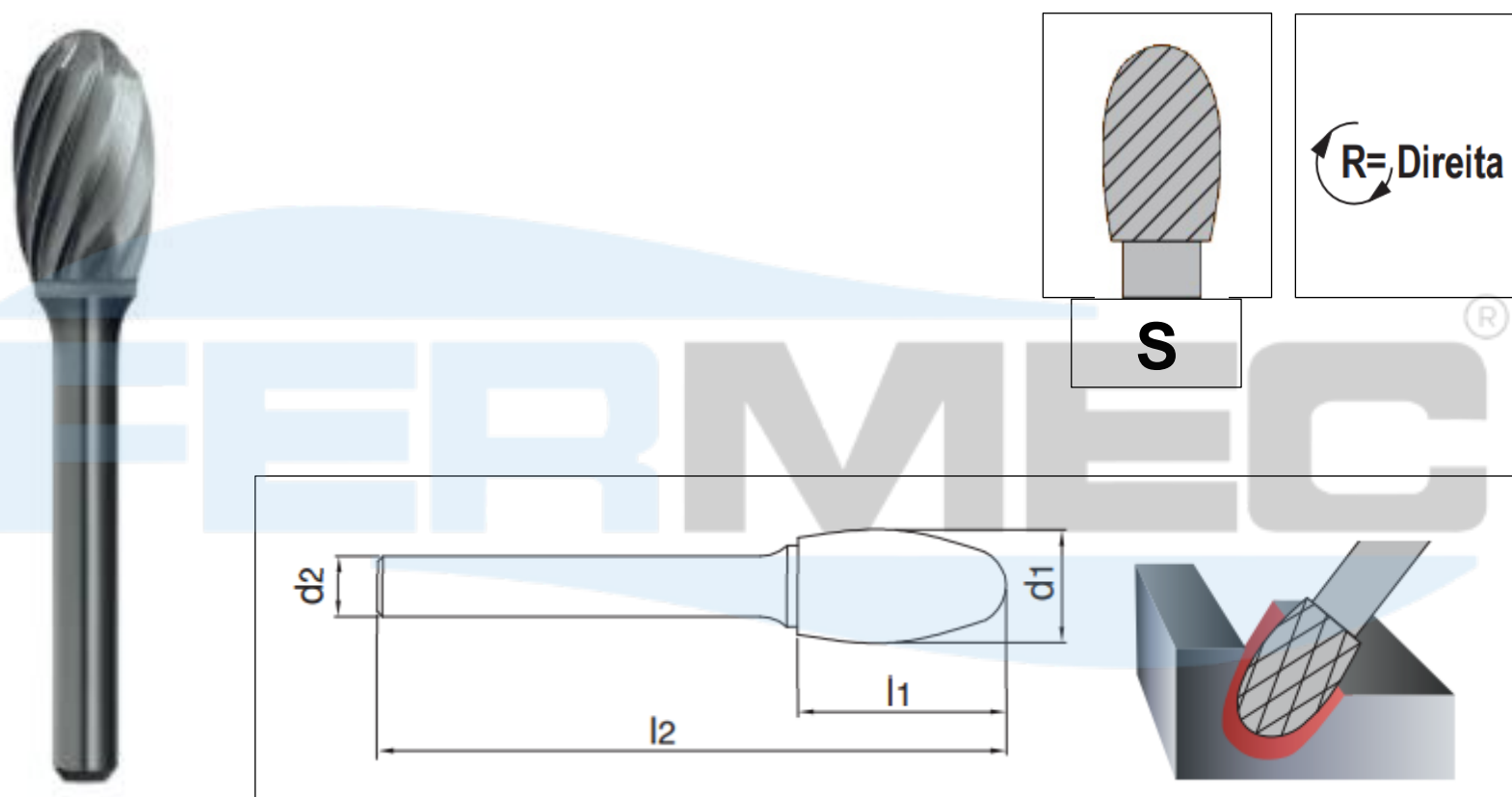

CÓDIGO	d1	d2	l1	l2
SE - 1M ALUM.	6	6	9,5	50
SE - 3M ALUM.	9,5	6	16	60
SE - 5M ALUM.	12,7	6	22	66
*SE - 6M ALUM.	16	6	25	69
*SE - 7M ALUM.	19	6	25	69

SF - FORMA DE ÁRVORE COM PONTA ESFÉRICA ALUMÍNIO

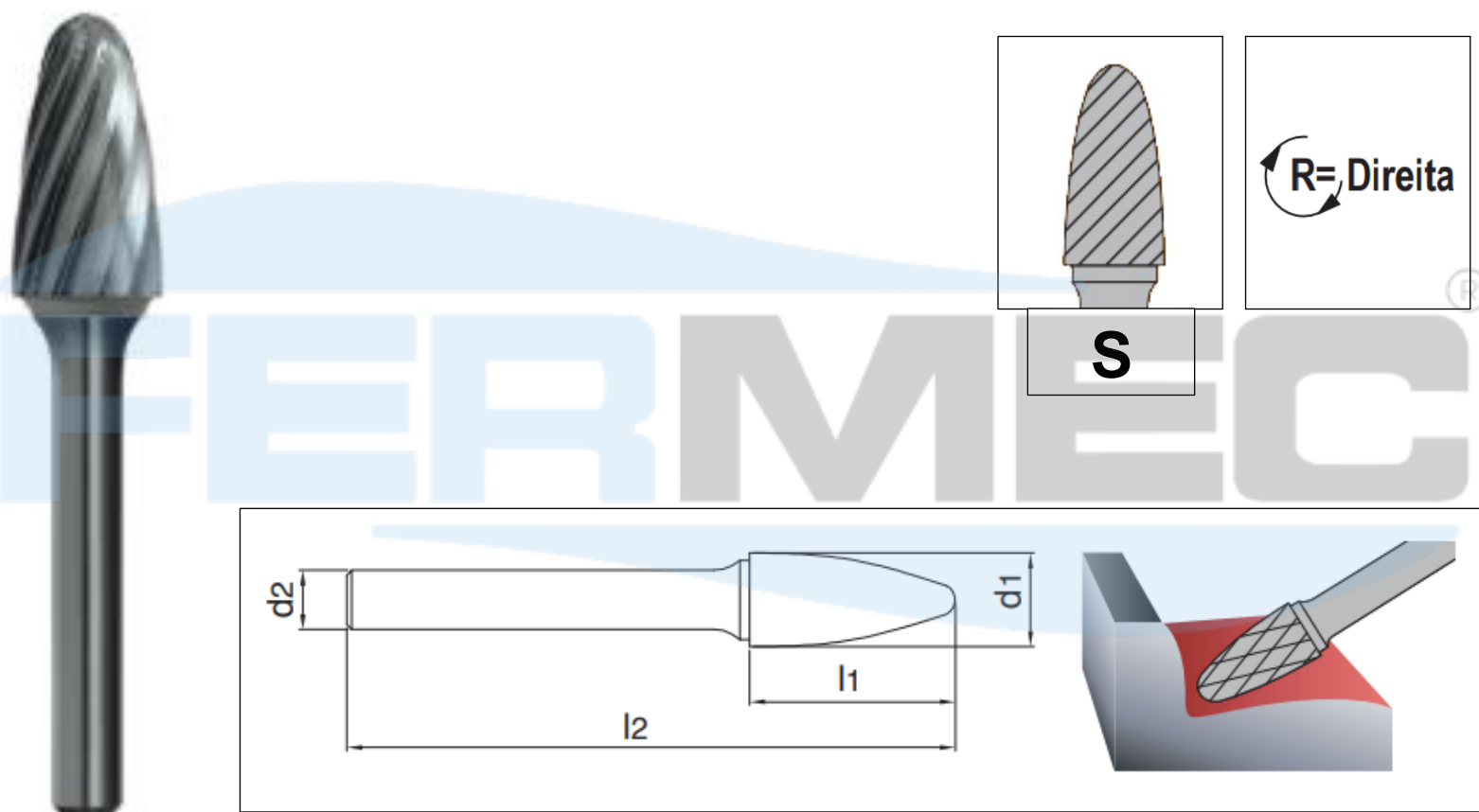

CÓDIGO	d1	d2	l1	l2
SF - 1M ALUM.	6	6	19	50
SF - 3M ALUM.	9,5	6	19	63
SF - 5M ALUM.	12,7	6	25	69
*SF - 6M ALUM.	16	6	25	69
*SF - 14M ALUM.	19	6	32	76

SG - FORMA DE ÁRVORE COM PONTA AGUDA ALUMÍNIO

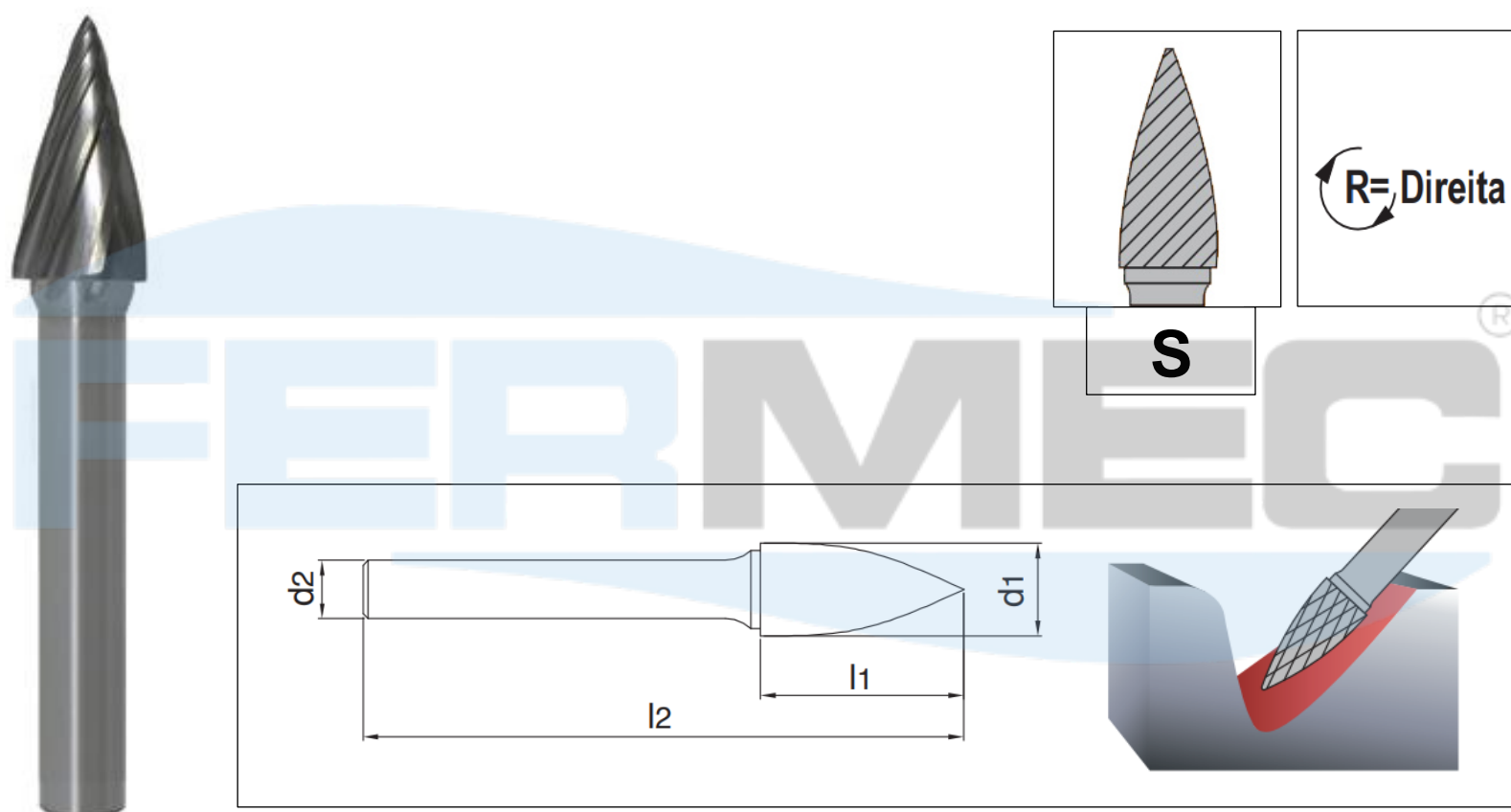

CÓDIGO	d1	d2	l1	l2
SG - 1M ALUM.	6	6	12,7	163
SG - 3M ALUM.	9,5	6	19	169
SG - 5M ALUM.	12,7	6	25	175

SL - FORMA CÔNICA COM PONTA ESFÉRICA ALUMÍNIO

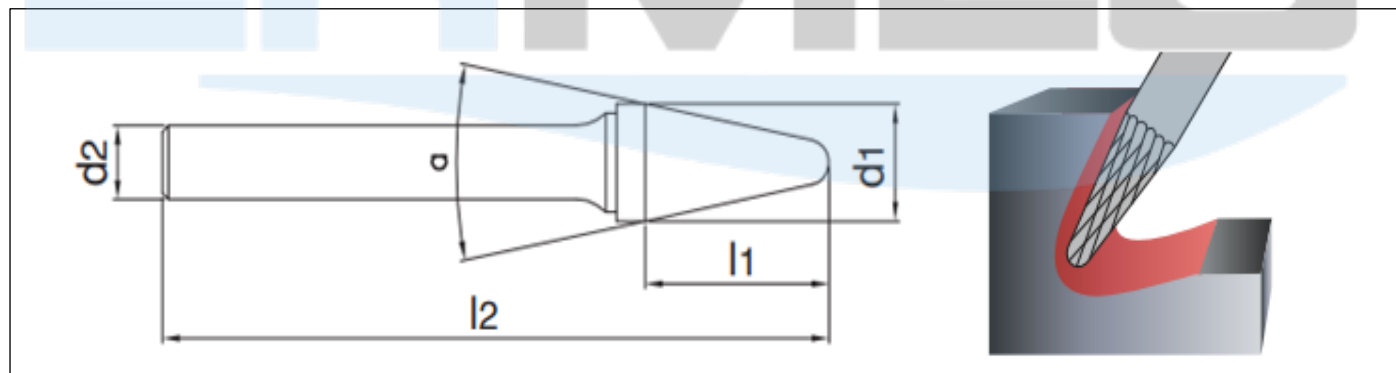
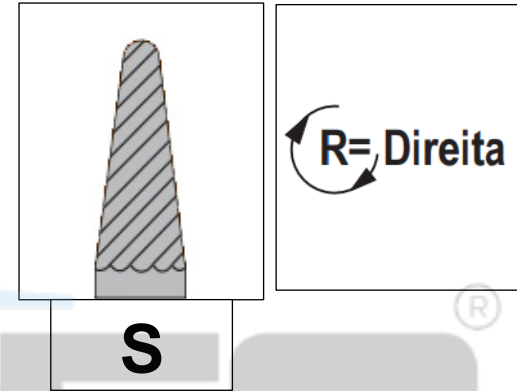

CÓDIGO	d1	d2	l1	l2	a°
SL - 3M ALUM.	9,5	6	27	74	14°
SL - 4M ALUM.	12,7	6	28	76	14°
*SL - 5M ALUM.	16	6	30	77	14°
*SL - 7M ALUM.	19	6	38	85	14°

REBARBADORES PARA FIBRA DE VIDRO

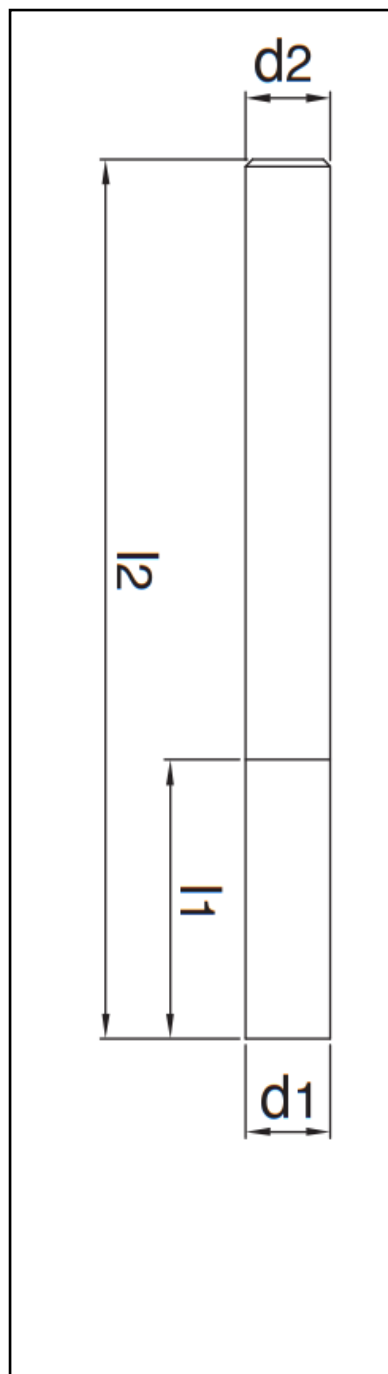

CÓDIGO	d1	d2	l1	l2
SGR - 1	1/16	1/8	3/16	1.1/2
SGR - 1 - 1	3/32	1/8	3/8	1.1/2
SGR - 2	1/8	1/8	1/2	1.1/2
SGR - 3	3/16	3/16	5/8	2
SGR - 4	3/16	1/4	5/8	2
SGR - 5	1/4	1/4	3/4	2
SGR - 6	1/4	1/4	3/4	2.1/2
SGR - 6 - 1	1/4	1/4	1	3
SGR - 7	5/16	5/16	1	2.1/2
SGR - 8	3/8	3/8	1	2.1/2
SGR - 9	1/2	1/2	1	3

REBARBADOR DE METAL DURO PARA FIBRA DE VIDRO

A - Sem Frontal

C - Fresa de topo

B - Lima rotativa de topo

D - Broca de topo

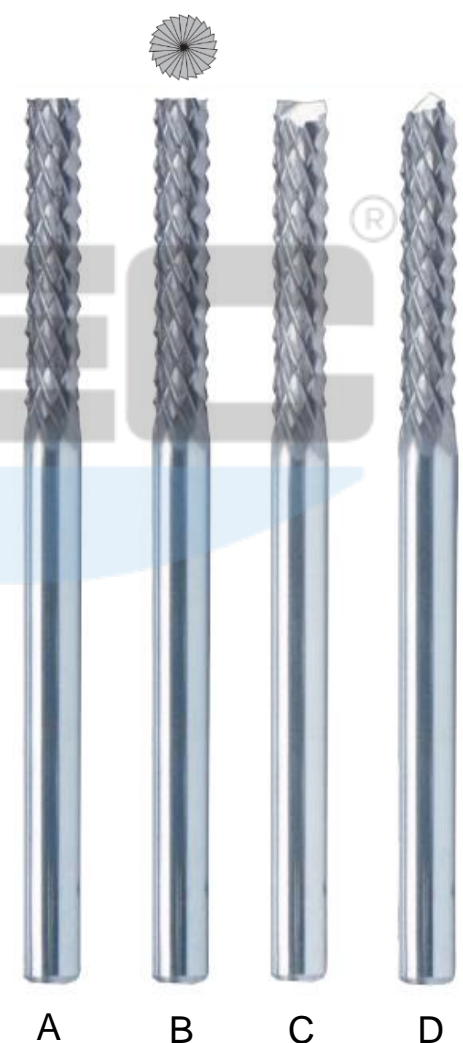
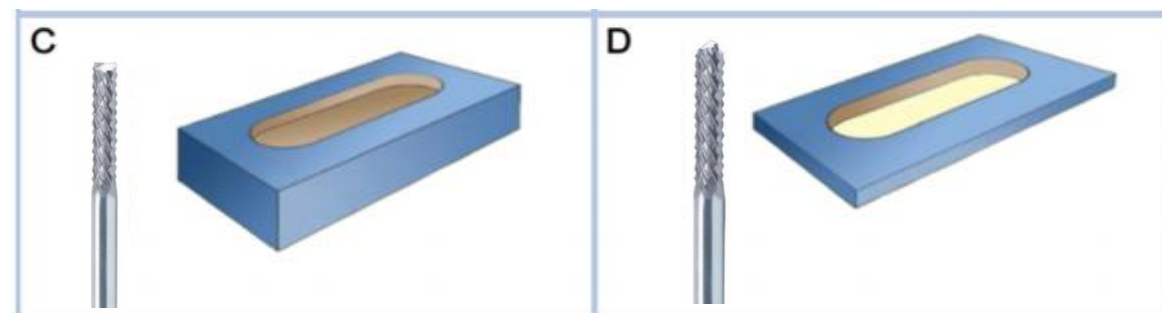
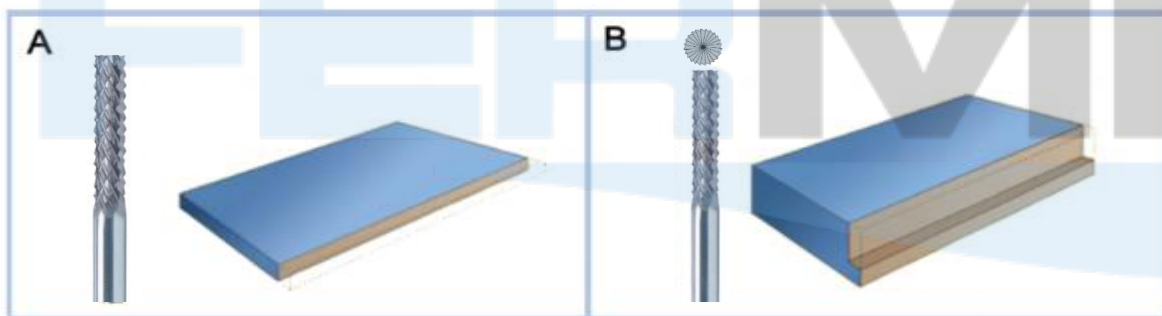

REBARBADORES PARA FIBRA DE VIDRO

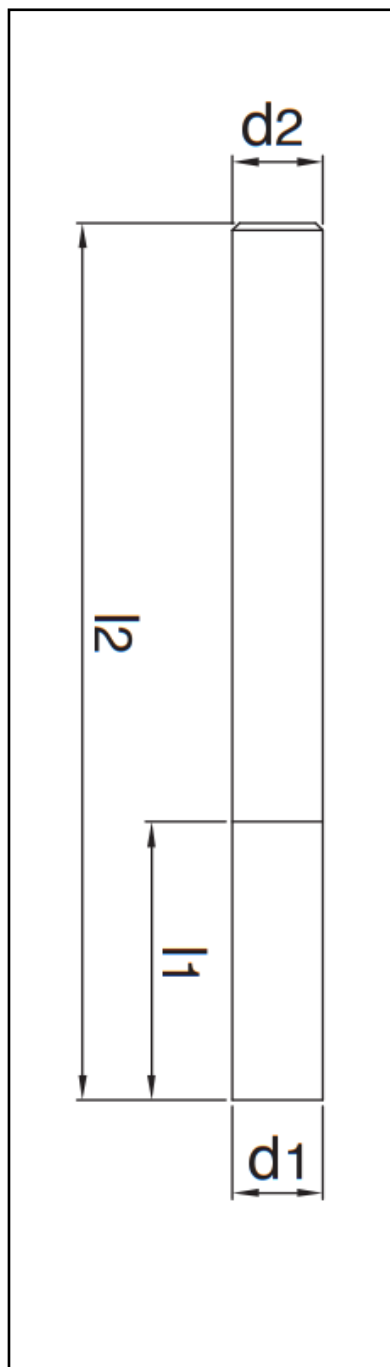

CÓDIGO	d1	d2	l1	l2
SGR - 1M	1,6	3	5	38
SGR - 1 - 1M	2,4	3	9,5	38
SGR - 2M	3	3	12	38
SGR - 3M	4	4	16	50
SGR - 4M	4	6	16	50
SGR - 5M	6	6	19	50
SGR - 6M	6	6	19	63
SGR - 6 - 1M	6	6	25	75
SGR - 7M	8	8	25	63
SGR - 8M	10	10	25	75
SGR - 9M	12	12	25	75

REBARBADOR DE METAL DURO PARA FIBRA DE VIDRO

A - Sem Frontal

C - Fresa de topo

B - Lima rotativa de topo

D - Broca de topo

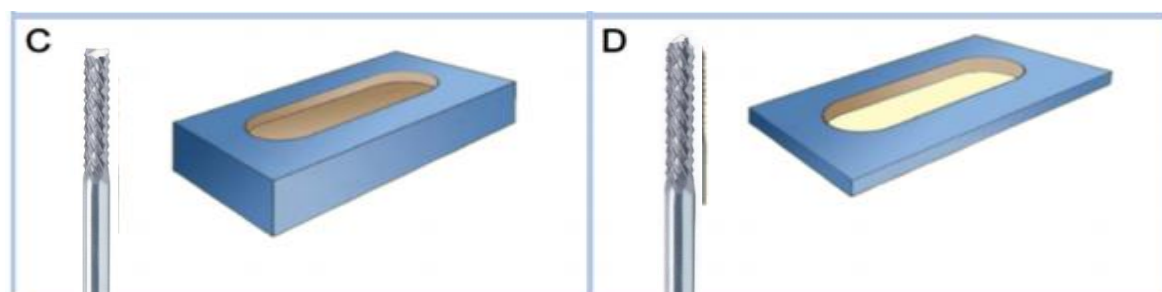
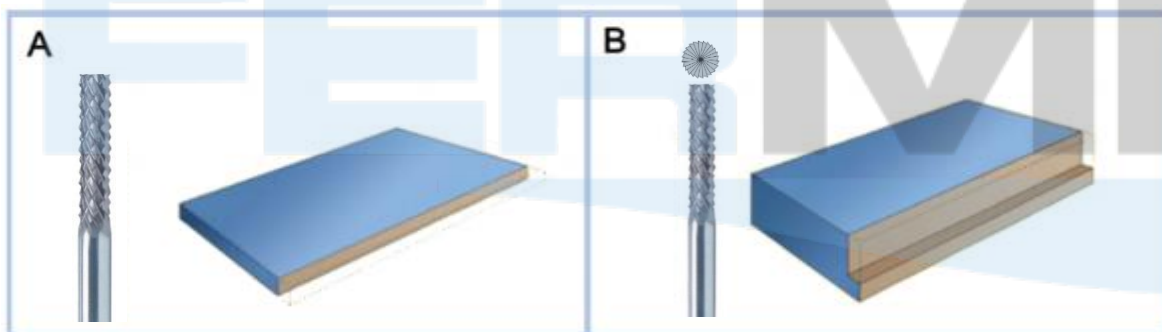



ENDEREÇO: Rua Rio Verde, 1829 - Vila Palmeiras - São Paulo/SP

CEP:02934-401

TELEFONE:+55 (11) 3978-5515

E-MAIL:fermec@fermec.com.br

SITE: WWW.FERMEC.COM.BR