

# FRESA DE TOPO RETO DE METAL DURO - 55HRC

## 4 CORTES - STANDARD

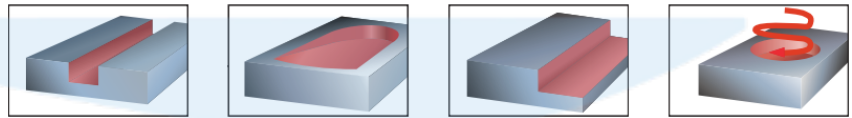
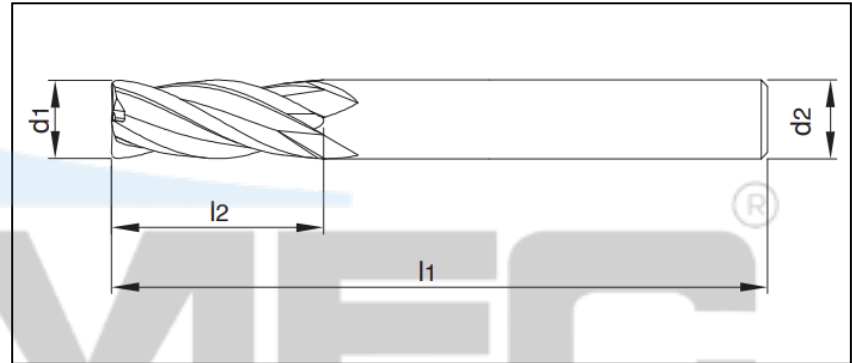
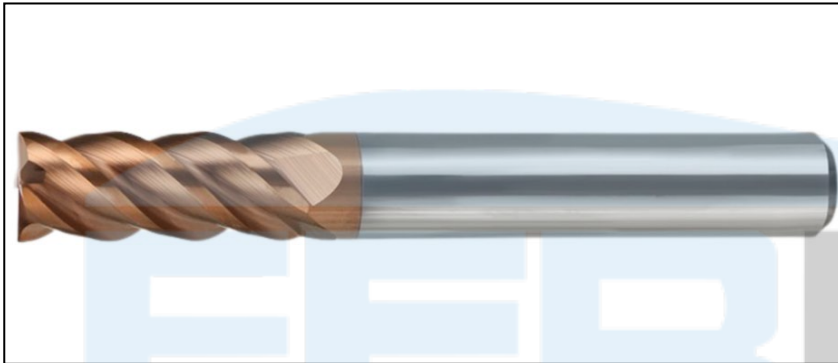

Código	d1	l2	l1	d2
F MD D 1MM 4C C/C 55HRC	1.0	3	50	3
F MD D 1MM 4C H4 C/C 55HRC	1.0	3	50	4
F MD D 1MM 4C H6 C/C 55HRC	1.0	3	50	6
F MD D 1.5MM 4C C/C 55HRC	1.5	4.5	50	3
F MD D 1.5MM 4C H4 C/C 55HRC	1.5	4.5	50	4
F MD D 2MM 4C C/C 55HRC	2.0	6	50	3
F MD D 2MM 4C H4 C/C 55HRC	2.0	6	50	4
F MD D 2MM 4C H6 C/C 55HRC	2.0	6	50	6
F MD D 2.5MM 4C C/C 55HRC	2.5	7	50	3
F MD D 2.5MM 4C H4 C/C 55HRC	2.5	7	50	4
F MD D 3MM 4C C/C 55HRC	3.0	8	50	3
F MD D 3MM 4C H4 C/C 55HRC	3.0	8	50	4
F MD D 3MM 4C H6 C/C 55HRC	3.0	8	50	6
F MD D 3.5MM 4C H4 C/C 55HRC	3.5	10	50	4
F MD D 4MM 4C C/C 55HRC	4.0	11	50	4
F MD D 4MM 4C H6 C/C 55HRC	4.0	11	50	6
F MD D 4.5MM 4C H6 C/C 55HRC	4.5	13	50	6
F MD D 5MM 4C C/C 55HRC	5.0	13	50	5
F MD D 6MM 4C C/C 55HRC	6.0	15	50	6
F MD D 6.5MM 4C H8 C/C 55HRC	6.5	15	50	8
F MD D 7MM 4C C/C 55HRC	7.0	17	60	7
F MD D 8MM 4C C/C 55HRC	8.0	20	60	8

# FRESA DE TOPO RETO DE METAL DURO - 55HRC

## 4 CORTES - STANDARD

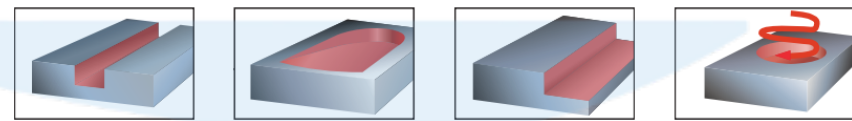
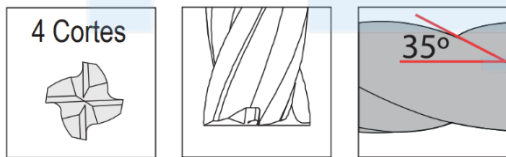
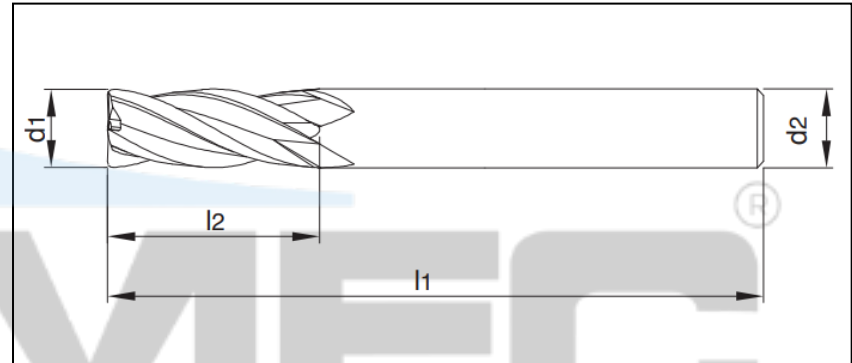
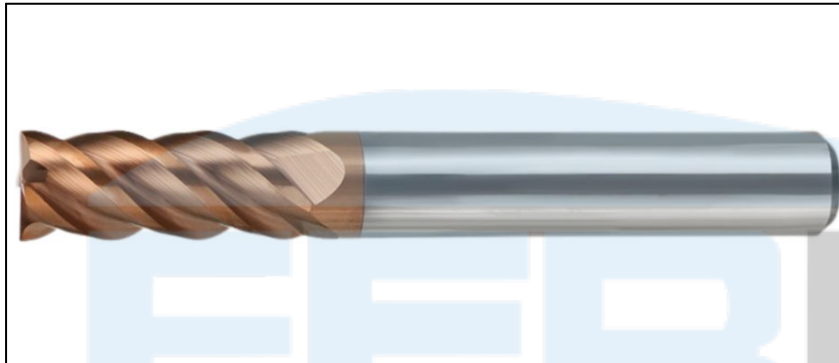

Código	d1	l2	l1	d2
F MD D 9MM 4C C/C 55HRC	9.0	23	75	9
F MD D 10MM 4C C/C 55HRC	10.0	30	75	10
F MD D 11MM 4C C/C 55HRC	11.0	28	75	11
F MD D 12MM 4C C/C 55HRC	12.0	30	75	12
F MD D 13MM 4C C/C 55HRC	13.0	33	100	13
F MD D 14MM 4C C/C 55HRC	14.0	35	100	14
F MD D 15MM 4C C/C 55HRC	15.0	38	100	15
F MD D 16MM 4C C/C 55HRC	16.0	40	100	16
F MD D 17MM 4C C/C 55HRC	17.0	40	100	17
F MD D 18MM 4C C/C 55HRC	18.0	40	100	18
F MD D 19MM 4C C/C 55HRC	19.0	40	100	19
F MD D 20MM 4C C/C 55HRC	20.0	40	100	20
F MD D 22MM 4C C/C 55HRC	22.0	40	100	22
F MD D 25MM 4C C/C 55HRC	25.0	40	100	25