

FRESA DE METAL DURO PARA CHANFRAR

4 CORTES

TiAIN

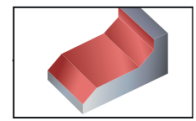
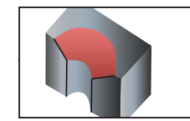
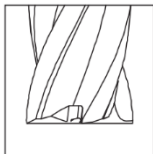
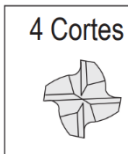
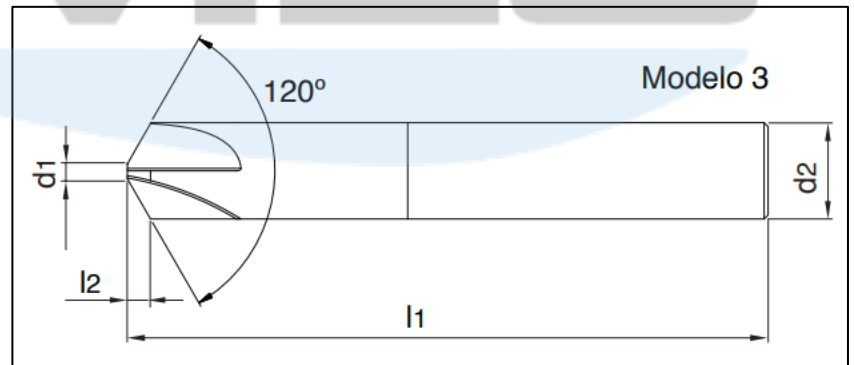
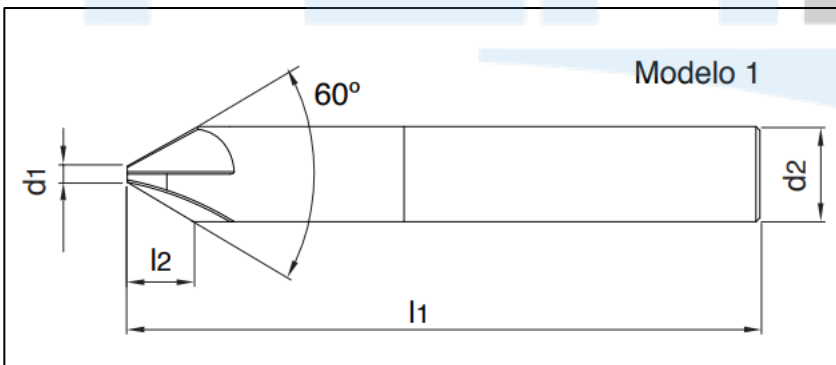
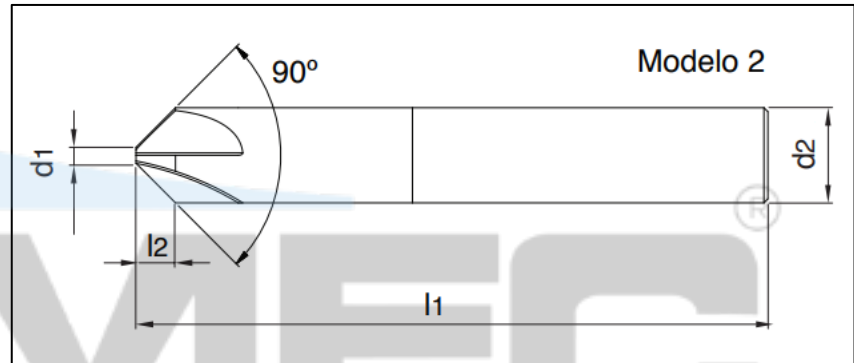

Código	d1	l2	l1	d2	Ângulo
F MD D 1MM 4C 90° Chanfrar H4 S/C	1	1.5	50	4	90°
F MD D 2MM 4C 60° Chanfrar H6 S/C	2	3	57	6	60°
F MD D 2MM 4C 90° Chanfrar H6 S/C	2	2	57	6	90°
F MD D 2MM 4C 120° Chanfrar H6 S/C	2	1	57	6	120°
F MD D 2MM 4C 60° Chanfrar H8 S/C	2	5	63	8	60°
F MD D 2MM 4C 90° Chanfrar H8 S/C	2	3	63	8	90°
F MD D 2MM 4C 120° Chanfrar H8 S/C	2	1	63	8	120°
F MD D 2MM 4C 60° Chanfrar H10 S/C	2	7	72	10	60°
F MD D 2MM 4C 90° Chanfrar H10 S/C	2	4	72	10	90°
F MD D 2MM 4C 120° Chanfrar H10 S/C	2	2	72	10	120°
F MD D 2MM 4C 60° Chanfrar H12 S/C	2	8	80	12	60°
F MD D 2MM 4C 90° Chanfrar H12 S/C	2	5	80	12	90°
F MD D 2MM 4C 120° Chanfrar H12 S/C	2	2	80	12	120°