

# FRESA DE METAL DURO PARA MDF UP CUT

## 2 CORTES

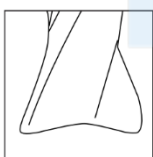
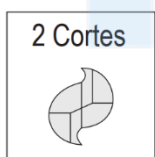
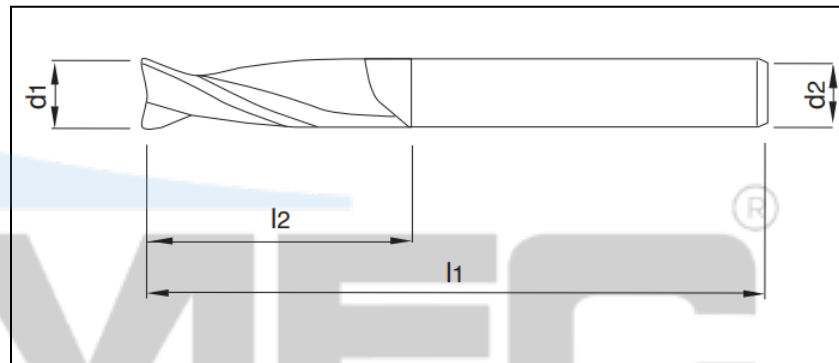
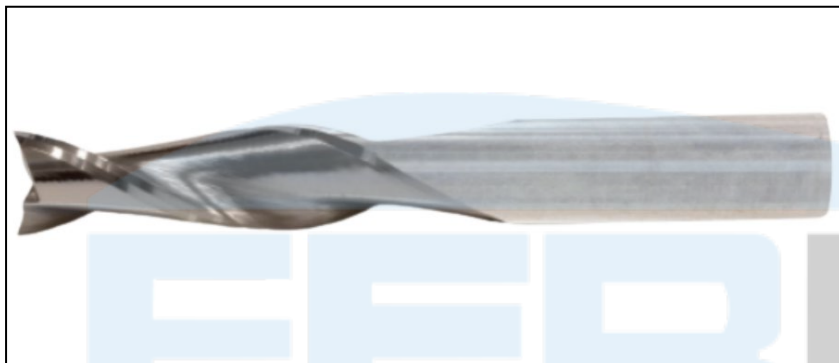

Código	d1	l2	l1	d2
F MD D 3MM 2C UP CUT S/C	3.0	12	38	3
F MD D 3MM 2C UP CUT H6 S/C	3.0	12	50	6
F MD D 4MM 2C UP CUT S/C	4.0	16	50	6
F MD D 5MM 2C UP CUT S/C	5.0	20	64	5
F MD D 6MM 2C UP CUT S/C	6.0	25	64	6
F MD D 8MM 2C UP CUT S/C	8.0	25	64	8
F MD D 10MM 2C UP CUT S/C	10.0	35	76	10
F MD D 12MM 2C UP CUT S/C	12.0	35	76	12